



NISO STS 1.0

IEC/ISO Coding Guidelines



Table of Contents

1	Maintenance	7
2	Legal Terms	7
3	General.....	7
3.1	Scope of this document	7
3.2	Coding Guidance.....	7
3.3	Tagging differences between ISO and IEC.....	8
3.4	Formatting of elements and attributes.....	9
3.5	Multilingual documents	9
4	Structure	9
4.1	General.....	9
4.2	Front matter.....	11
4.2.1	General.....	11
4.2.2	Metadata	12
4.2.3	Foreword.....	14
4.2.4	Introduction	15
4.3	Body.....	17
4.3.1	General.....	17
4.3.2	Clauses.....	17
4.3.3	Types of clause	19
4.4	Back matter	24
4.4.1	General.....	24
4.4.2	Annexes	24
4.4.3	Bibliography.....	26
4.4.4	Index.....	30
4.4.5	Footnotes.....	31
5	Content.....	32
5.1	Spaces, punctuation and formatting.....	32
5.2	Using <label> and <title>.....	33
5.3	Using <p>	34
5.4	Symbols.....	34
5.5	Formatting text with <styled-content>	34
5.5.1	<i>@style-type / @specific-use</i>	34
5.5.2	<i>@style</i>	37
5.6	Notes and examples.....	37



5.6.1	Notes in tables, figures and formulae	39
5.6.2	Notes with label “Warning / Important / Caution”	40
5.7	Lists	40
5.7.1	Lists with labels (ordered / unordered lists).....	42
5.7.2	Lists without labels	42
5.8	Specific text alignments	43
5.9	Quotations	44
5.10	Graphics.....	44
5.11	Boxed text.....	46
5.12	Code.....	48
5.13	Preformatted text	49
5.14	Editing instructions (deletions, additions) – IEC only.....	49
6	Tables	50
6.1	General.....	50
6.2	Table headers.....	51
6.3	Layout of content inside cells	52
6.4	Formal vs informal tables.....	52
6.5	Informal tables.....	53
6.6	Formal tables.....	53
6.6.1	General.....	53
6.6.2	Designation.....	53
6.6.3	Table notes and footnotes	53
6.6.4	Unit statements in table headers.....	56
6.6.5	General unit statements in tables.....	57
7	Formulae and equations.....	57
7.1	Elements and attributes.....	57
7.2	Numbered formulae	58
7.3	Unnumbered formulae	58
7.4	Groups of formulae	59
7.5	Formula keys	61
7.6	MathML.....	62
8	Figures	63
8.1	Elements and attributes.....	63
8.2	Sub-figures and multiple graphics within a figure.....	63
8.3	Figure key	64
8.4	Unit statements in figures	64



8.5	Sample coding of a figure	66
9	Terms and definitions.....	69
9.1	Subclauses inside a "Terms and Definitions" clause.....	69
9.2	Usage of TBX vs. <term-display>.....	70
9.2.1	General.....	70
9.2.2	TBX (based exclusively on semantic information).....	70
9.2.3	<term-display> (more appearance oriented)	70
9.3	Terminological entries in TBX.....	71
9.3.1	Terms and definitions	71
9.3.2	Definitions.....	72
9.3.3	Terms and additional information on them.....	72
9.3.4	Examples in terminology	74
9.3.5	Notes in terminology	75
9.3.6	Cross-references between terms in the Terms and definitions clause.....	75
9.3.7	References to the other sections of the document [within TBX coding].....	76
9.3.8	Coding the source related to the terminological entry.....	76
9.3.9	Subject fields of a terminological entry	77
9.4	Using <term-display> instead of TBX.....	77
10	References	79
10.1	Internal (Cross) References.....	79
10.1.1	General.....	79
10.1.2	Cross-references to Sections, Tables, Figures and Formulae	80
10.1.3	Cross-references to terms	80
10.1.4	Footnotes.....	81
10.1.5	Cross-references to abbreviations.....	82
10.1.6	Cross-references to items in bibliography.....	83
10.2	External References.....	84
10.2.1	Reference to an external standard.....	84
10.2.2	Reference to a section, figure etc. in an external standard	84
10.2.3	URL.....	85
Annex A	Metadata usage	86
A.1	ISO.....	86
A.2	IEC.....	87
A.3	National metadata usage	88
Annex B	Coding Tables in NISO STS.....	89
B.1	General.....	89



B.2	Text alignment of tables	89
B.2.1	Default vertical alignment of a table text.....	89
B.2.2	Default horizontal alignment of a table text.....	90
B.2.3	Default horizontal alignment of table header data.....	91
B.2.4	Merged cells	91
B.2.5	Line breaks and lists within a table.....	91
B.3	Other instructions	93
B.3.1	Landscape tables.....	93
B.3.2	Tables lines via attributes	94
B.3.3	Using table rules attribute	94
B.3.4	Table frames	96
B.3.4	Border styling.....	98
B.3.5	Alignment of Table	99
B.3.6	Text rotation	99
Annex C	Amendments	100
IEC	amendments	100
Editing	instructions.....	100
ISO	amendments	102
Annex D	105
IEC	Corrigenda	105
IEC	Interpretation Sheets (ISH)	105
IEC	Software supplements	105
Annex E	IEC ID scheme	107
Annex F	ISO ID scheme	109



Update information

Version	Date	Authors	Changes
v. 0.91	2020-02-12	Kylie Rodier (ISO) Serge Juillerat (ISO) Alisdair Menzies (IEC)	<ul style="list-style-type: none">- update document with decisions taken during Joint XML user group meetings- IEC: update with new tagging decided during IEC Reference group meetings
v. 1.0	2021-01-01	Anja Bielfeld (IEC)	<ul style="list-style-type: none">- update with corrections- finalise document

All rights reserved. The structure and contents of these Coding Guidelines are copyright of IEC and ISO and are subject to certain conditions of copyright. Published by International Electrotechnical Commission (IEC), 3 rue de Varembe, 1211 Geneva 20, Switzerland and International Organization for Standardization (ISO), Chemin de Blandonnet 8, 1214 Vernier, Geneva, Switzerland.



1 Maintenance

Suggestions for updates will be considered on a regular basis. Please address them to

helpdesk@iec.ch
helpdesk@iso.org

Our objective is to have a document that is as stable as possible. Therefore, in considering requests, we'll make the distinction between critical updates and improvements consisting of one or several updates.

2 Legal Terms

Although these NISO STS 1.0 IEC/ISO Coding Guidelines represent considered guidance for IEC/ISO members (and their respective providers, if any) on the XML conversion and production process, there is no guarantee that this guidance is comprehensive or error-free. These Coding Guidelines are supplied "as-is" without warranty of any kind, either expressed or implied. Any conversion and production of XML from the original IEC and/or ISO source publication(s), including tagging, erroneous or otherwise, done pursuant to these Coding Guidelines is for reference purposes only and shall not affect the meaning or interpretation of the respective IEC and/or ISO source publication(s), including any technical requirements. No liability is assumed by IEC or ISO including for incidental or consequential damage resulting from the use of these Coding Guidelines and any elements of the conversion and production process made thereunder.

All rights reserved. The structure and contents of these Coding Guidelines are copyright of IEC and ISO and are subject to certain conditions of copyright. Published by International Electrotechnical Commission (IEC), 3 rue de Varembe, 1211 Geneva 20, Switzerland and International Organization for Standardization (ISO), Chemin de Blandonnet 8, 1214 Vernier, Geneva, Switzerland.

3 General

3.1 Scope of this document

This document describes the tagging of IEC / ISO standards-type documents in XML. It gives recommendations for the harmonized tagging of content in the IEC / ISO environment and can be used for the following purposes:

- as a basis for IEC / ISO members for their conversion and production process
- to help conversion providers set up the conversion from unstructured content to XML according to the NISO Standards Tag Suite (NISO STS)

This document applies to NISO STS 1.0 (October 2017). Versions of this document refer to the implementation status at IEC and ISO, not to NISO STS versions.

3.2 Coding Guidance

NISO STS is based on ANSI/NISO Z39.96 (JATS) and is backwards compatible with ISO STS.

It provides a common XML format that developers, publishers, and distributors of standards, including national standards bodies, regional and international standards bodies, and standards development organizations, can use to publish and exchange full-text content and metadata of standards.



The full description as well as supporting materials can be found at <https://www.niso-sts.org/>. Elements and attributes are described in more depth at <https://www.niso-sts.org/TagLibrary/niso-sts-TL-1-0-html/index.html>.

Structures are provided to encode both the normative and non-normative content of standards, adoptions of standards, and standards-like documents that are produced by standards organizations.

ISO/IEC standards should be drafted according to the ISO/IEC Directives "Rules for the structure and drafting of International Standards", in their current edition. Because the directives have changed over time and may not have always been followed faithfully, past standards may have been coded differently, for instance, a clause described as required may be absent from an older standard, and other such deviations from the latest directives may exist.

Going forward, these past standards should not be used as reference or precedence for exotic coding.

Tagging to be used only where required in legacy standards will be marked as "Legacy tagging".

Cases where tagging is under investigation for optimisation will be marked as "Under investigation for future implementation".

3.3 Tagging differences between ISO and IEC

ISO and IEC strive to use identical tagging wherever contents are identical. For those cases where contents or usages are different, the ISO variant is highlighted in red, the IEC one in blue.

ISO variant ...
IEC variant ...

A recurring difference is that of IDs – where ISO is using underscores in IDs, IEC is using dashes. For example:

ISO <code>@id="sec_foreword"</code>
IEC <code>@id="sec-foreword"</code>

An online standards development tool is currently being developed at ISO and IEC. In this context, arbitrary unique IDs will be assigned and managed by the tool. Editorial notes

Where comments on the structure of standards (e.g. from the ISO/IEC Directives, Part 2) or other background information is provided in addition to coding instructions, it will be preceded by the words "Editorial note" and set in a light grey box, like this:

Editorial note ...



3.4 Formatting of elements and attributes

Throughout the text, XML elements are written in angle brackets and formatted in bold, attributes are prefixed by @ and formatted in italics, as illustrated below:

<element>

@attribute

3.5 Multilingual documents

For multilingual documents, *@xml:lang* should be used on the most outer block level element. For example, if a document has alternating sections in English and French, then it is sufficient to provide the *@xml:lang="en"* or *@xml:lang="fr"* in the top level **<sec>** element only.

4 Structure

4.1 General

A standard or standards-type document is divided into three parts:

- front matter
- body
- back matter

The complete document should be coded within the root **<standard>**. For example:

```

<?xml version="1.0" encoding="UTF-8"?>
<standard xmlns:mml="http://www.w3.org/1998/Math/MathML" xmlns:tbx="urn:iso:std:iso:30042:ed-1"
xmlns:xlink="http://www.w3.org/1999/xlink">
  <front>
    <std-meta>
      <title-wrap xml:lang="en">
        <intro>.....</intro>
        <main>.....</main>
        <compl>.....</compl>
        <full>.....</full>
      </title-wrap>
      <title-wrap xml:lang="fr">
        <intro>.....</intro>
        <main>.....</main>
        <compl>.....</compl>
        <full>.....</full>
      </title-wrap>
      <proj-id>.....</proj-id>
      <std-ident>
        <originator>ISO</originator>
        <doc-type>IS</doc-type>
        <doc-number>9512</doc-number>
        <part-number/>
        <edition>3</edition>
        <version>1</version>
      </std-ident>
      <std-org std-org-type="sdo">
        <std-org-abbrev>ISO</std-org-abbrev>
      </std-org>
      <content-language>en</content-language>
      <std-ref type="dated">ISO/DIS 9512</std-ref>
      <std-ref type="undated">ISO/DIS 9512</std-ref>
      <doc-ref>ISO/DIS 9512 (en)</doc-ref>
      <release-date>2018-08-06</release-date>
      <meta-date type="vote-start">2018-08-06</meta-date>
      <meta-date type="vote-end">2018-10-29</meta-date>
      <comm-ref>ISO/TC 126/SC 1</comm-ref>
      <secretariat>AFNOR</secretariat>
      <ics>65.160</ics>
      <page-count count="18"/>
      <std-xref type="revises">
        <std-ref>ISO 9512:2002</std-ref>
      </std-xref>
      <permissions>
        <copyright-statement>All rights reserved</copyright-statement>
        <copyright-year>2018</copyright-year>
        <copyright-holder>ISO</copyright-holder>
      </permissions>
      <self-uri>.....</self-uri>
      <custom-meta-group>
        <custom-meta>
          <meta-name>special-voting-rule</meta-name>
          <meta-value>NO FDIS BALLOT</meta-value>
        </custom-meta>
        <custom-meta>
          <meta-name>price-ref-pages</meta-name>
          <meta-value>18</meta-value>
        </custom-meta>
        <custom-meta>
          <meta-name>generation-date</meta-name>
          <meta-value>2018-06-08 07:42:48</meta-value>
        </custom-meta>
      </custom-meta-group>
    </iso-meta>
  </front>
</standard>

```

Front - Metadata



The following front and back matter content are not captured in the XML:

- cover pages
- table of contents
- page headers and footers containing the name of the document, page numbers etc.
- index if it refers to page numbers (if coded, indexes refer to marked-up elements)

The copyright notices listed in the footer in the PDF document should be captured in the metadata section using **<permissions>**.

4.2 Front matter

4.2.1 General

<front> is required in ISO/IEC standards and can comprise the following front matter:

- standards organizations metadata
- other optional national metadata
- a foreword
- an introduction

The front matter of a standard may contain:



- document-level metadata (**<std-doc-meta>**)
- standards organization metadata (in one or more of the elements **<std-meta>**, **<iso-meta>**, **<reg-meta>**, or **<nat-meta>**)
- prose material such as notes and sections, particularly as used for placeholder elements not yet articulated in NISO STS (for example, patents or particular copyright statements) or for older content with different structures

4.2.2 Metadata

ISO

Legacy tagging

<iso-meta> contains ISO-specific metadata about the document in legacy content.

For NISO STS implementation going forward, this will be **<std-meta>**.

IEC

<std-meta> contains IEC-specific metadata about the document.

No organization metadata should be captured within **<std-doc-meta>**. Instead, **<std-meta>**, **<iso-meta>**, **<reg-meta>**, or **<nat-meta>** should be used as appropriate, with relevant titles, copyright statements, dates, etc. Organization-specific metadata in **<std-meta>** will override relevant data in **<std-doc-meta>**. This element allows for accurate capture of standards organizations' data when publishing or adopting standards.

To capture the copyright information for the current document in the metadata, use the **<permissions>** element. For example:

```
<std-meta>
.....
  <permissions>
    <copyright-statement>All rights reserved</copyright-statement>
    <copyright-year>2011</copyright-year>
    <copyright-holder>ISO</copyright-holder>
  </permissions>
</std-meta>
```

For multiple copyrights, ISO and IEC use different coding:

ISO

All copyright statements are summed up in one **<permissions>** element, e.g.

```
<permissions>
<copyright-statement>All rights reserved</copyright-statement>
<copyright-year>2019</copyright-year>
<copyright-holder>ISO</copyright-holder>
</permissions>
```

Under investigation for future implementation:



ISO is investigating the inclusion of the full copyright statement.

IEC

Copyright statements are divided into individual **<permissions>** elements within **<std-meta>**. These copyright statements must not be overwritten in adoptions!

```
<permissions>
  <copyright-statement>
    <inline-graphic xlink:href="asset/iso_7010_w001.png"
xmlns:xlink="http://www.w3.org/1999/xlink"/>THIS PUBLICATION IS COPYRIGHT PROTECTED
Copyright &#169; 2017 IEC, Geneva, Switzerland</copyright-statement>
    <copyright-year>2017</copyright-year>
    <copyright-holder>IEC</copyright-holder>
    <license>
      <license-p>All rights reserved. Unless otherwise specified, no part of this publication
may be reproduced or utilized in any form or by any means, electronic or mechanical,
including photocopying and microfilm, without permission in writing from either IEC or
IEC&#8217;s member National Committee in the country of the requester. If you have any
questions about IEC copyright or have an enquiry about obtaining additional rights to this
publication, please contact the address below or your local IEC member National Committee
for further information.</license-p>
      <license-p>
        <address>
          <addr-line>IEC Central Office, 3, rue de Varemb&#233;, CH-1211 Geneva 20,
Switzerland, Tel.: +41 22 919 02 11, info@iec.ch, www.iec.ch</addr-line>
        </address>
      </license-p>
    </license>
  </permissions>
</permissions>
<copyright-statement>
  <inline-graphic xlink:href="asset/iso_7010_w001.png"
xmlns:xlink="http://www.w3.org/1999/xlink"/>COPYRIGHT PROTECTED DOCUMENT &#169; ISO
2017</copyright-statement>
  <copyright-year>2017</copyright-year>
  <copyright-holder>ISO</copyright-holder>
  <license>
    <license-p>All rights reserved. Unless otherwise specified, or required in the context
of its implementation, no part of this publication may be reproduced or utilized otherwise
in any form or by any means, electronic or mechanical, including photocopying, or posting on
the internet or an intranet, without prior written permission. Permission can be requested
from either ISO at the address below or ISO&#8217;s member body in the country of the
requester.</license-p>
    <license-p>
      <address>
        <addr-line>ISO copyright office, CP 401 . Ch. de Blandonnet 8, CH-1214 Vernier,
Geneva, Phone: +41 22 749 01 11, Fax: +41 22 749 09 47, Email: copyright@iso.org</addr-line>
      </address>
    </license-p>
  </license>
</copyright-statement>
</permissions>
```

The copyright note in the PDF footer should be coded as below. The grouping is based on the different lines used in the footer.

```
© ANFIA, © FIEV, © SMMT, © VDA, © Chrysler, © Ford Motor Company, © General Motors Corp. – All rights reserved
© PSA Peugeot Citroën, © Renault – All rights reserved
```



is coded as:

```

<permissions>
  <copyright-statement>All rights reserved</copyright-statement>
  <copyright-year>2009</copyright-year>
  <copyright-holder>ISO</copyright-holder>
</permissions>
<permissions>
  <copyright-statement>All rights reserved</copyright-statement>
  <copyright-holder>ANFIA</copyright-holder>
  <copyright-holder>FIEV</copyright-holder>
  <copyright-holder>SMMT</copyright-holder>
  <copyright-holder>VDA</copyright-holder>
  <copyright-holder>Chrysler</copyright-holder>
  <copyright-holder>Ford Motor Company</copyright-holder>
  <copyright-holder>General Motors Corp.</copyright-holder>
</permissions>
<permissions>
  <copyright-statement>All rights reserved</copyright-statement>
  <copyright-holder>PSA Peugeot Citroën</copyright-holder>
  <copyright-holder>Renault</copyright-holder>
</permissions>

```

For translated standards, there is no need to capture extra phrases such as "Official translation/Traducción oficial/Traduction officielle" before the organization copyright.

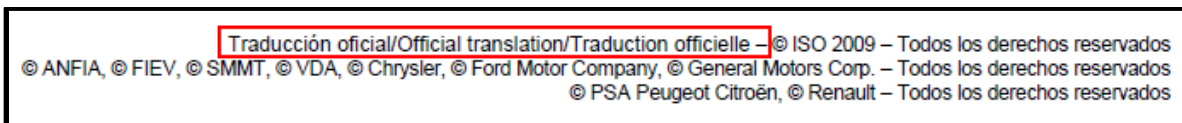

If specific conditions exist under which the content may be used, accessed, and distributed, use the **<license>** element within **<permissions>** to provide the relevant license statement or copyright conditions.

4.2.3 Foreword

Editorial note
The foreword is generally required and unnumbered and should contain no tables or graphics.

This is the first titled clause. It is coded as **<sec>**. For a more detailed description of **<sec>** in general, see 4.3.2.

Attributes

@sec-type="foreword"

ISO <i>@id="sec_foreword"</i>
IEC <i>@id="sec-foreword"</i>

For example:

Foreword

ISO (the International Organization for Standardization) is a worldwide federation of national standards bodies (ISO member bodies). The work of preparing International Standards is normally carried out through ISO technical committees. Each member body interested in a subject for which a technical committee has been established has the right to be represented on that committee. International organizations, governmental and non-governmental, in liaison with ISO, also take part in the work. ISO collaborates closely with the International Electrotechnical Commission (IEC) on all matters of electrotechnical standardization.

should be coded as

```
<sec id="sec_foreword" sec-type="foreword">
```

4.2.4 Introduction

Editorial note

If present, the introduction should follow the foreword and is generally not numbered. In certain cases, introductions can contain subclauses, which will then be numbered “0.1 / 0.2” etc.

The introduction is coded as `<sec>`. For a more detailed description of `<sec>` in general, see 4.3.2.

Attributes

`@sec-type="intro"`

ISO

- unnumbered introduction: `@id="sec_intro"`
- numbered introduction: `@id="sec_0"`
- subclauses of the introduction: `@id="sec_0.1"`

For example:

- a) Unnumbered introduction with no subclauses:

Introduction

The Quality management principles underlying the ISO 9000 family of standards (of which the ISO 10000 series form a part) emphasize the importance of human resource management and the need for appropriate training. They recognize that customers are likely to both respect and value an organization's commitment to its human resources and its ability to demonstrate the strategy used to improve the competence of its personnel.

Personnel at all levels should be trained to meet the organization's commitment to supply products of a required quality in a rapidly changing market place where customer requirements and expectations are increasing continuously.

should be coded as:

```

<sec id="sec_intro" sec-type="intro">
  <title>Introduction</title>
  <p>The Quality management principles underlying the <std std-id="iso:std:iso:9000:en"
  type="undated"><std-ref>ISO 9000</std-ref> family of standards (of which the <std><std-
  ef>ISO 10000</std-ef></std> series form a part) emphasize the importance of human resource
  management and the need for appropriate training. They recognize that customers are likely
  to both respect and value an organization's commitment to its human resources and its
  ability to demonstrate the strategy used to improve the competence of its personnel.</p>
  <p>Personnel at all levels should be trained to meet the organization's commitment to
  supply products of a required quality in a rapidly changing market place where customer
  requirements and expectations are increasing continuously.</p>
</sec>

```

b) Unnumbered introduction with sub-clauses:

If the introduction is not numbered but has sub-clauses, for the introduction use as above:

```

<sec id="sec_intro" sec-type="intro">

```

and for the sequence of the sub-clauses use:

```

<sec id="sec_intro.1">
  <sec id="sec_intro.1.1">

```

and so on.

c) Introduction with numbered subclauses:

Introduction

0.1 General

0.1.1 This Technical Report provides guidance to assist in the development, implementation and maintenance of quality management systems that aim to meet the requirements of ISO 13485 for organizations that design and develop, produce, install and service medical devices, or that design, develop and provide related services. It provides guidance related to quality management systems for a wide variety of medical devices and related services. Such medical devices include active, non-active, implantable and non-implantable medical devices and *in vitro* diagnostic medical devices.

should be coded as:

```

<sec id="sec_0" sec-type="intro">
  <title>Introduction</title>
  <sec id="sec_0.1">
    <label>0.1</label>
    <title>General</title>
    <sec id="sec_0.1.1">
      <label>0.1.1</label>
      <p> This Technical report.....</p>
      .....
    </sec>
  </sec>

```

IEC

- unnumbered introduction: @id="sec-introduction"
- numbered introduction: @id="sec-introduction"

- subclauses of the introduction: `@id="sec-0.1"`

For example:

```
<sec id="sec-introduction" sec-type="intro">
<title>Introduction</title>
<p id="p-29">This introduction is not intended to be copied into the drafted detail
specification. Therefore it is positioned prior to the conventional document structure and
clause numbering range. It nevertheless contains normative requirements to the drafted
detail specification.</p>
<sec id="sec-0.1">
<label>0.1</label>
<title>Scope of this blank detail specification</title>
...
```

4.3 Body

4.3.1 General

The main textual portion of a standards document is usually captured in the `<body>` tag. The `<body>` is required in ISO/IEC documents.

It contains multiple clauses and subclauses (henceforth both will be referred to as "clauses" in this document, unless the differentiation is important). Clauses must be captured in `<sec>`, usually starting with clause 1 (normally "Scope"), followed by other sequentially and hierarchically numbered clauses.

For example: clauses 1.2.1 and 1.2.2 are within clause 1.2, which is within clause 1.

Legacy tagging

Legacy documents sometimes have non-standard subdivisions, such as chapters or other groupings of content. For these, `<sec>` is used.

4.3.2 Clauses

Editorial note

Usually, each clause has a title and a sequential number according to its hierarchical position in the document. Some subclauses do not have a title (see *Numbered paragraphs*).

Clauses are captured in a `<sec>` tag. They can contain the following:

- any type of content (text, table, graphic)
- subclauses

The clause number is coded as a `<label>` within `<sec>`.

The title of the clause is coded as a `<title>` within `<sec>`.

Attributes

`@sec-type` is dependent on the clause type (see *Types of clause*)

`@id` is based on the number of the clause; e.g. for clause 4.3:



ISO

`id="sec_4.3"`

IEC

`id="sec-4.3"`

For example:

5 Notation

5.1 This Recommendation | International Standard references the notation defined by ITU-T Rec. X.680 | ISO/IEC 8824-1, ITU-T Rec. X.682 | ISO/IEC 8824-3, W3C XML 1.0 and W3C XML Schema.

5.2 When it is necessary in the body of this Recommendation | International Standard to specify, either formally or in examples, the assignment of XER encoding instructions, the type prefix notation is generally used (but see 6.3 and 6.4). In Annex A, an XER encoding control section is used.

5.3 In this Recommendation | International Standard, **bold Courier** is used for ASN.1 notation and **bold Arial** is used for XSD notation and for XSD terms and concepts.

5.4 The XSD Schemas used in the examples in this Recommendation | International Standard use the prefix **xsd:** to identify the XSD namespace.

is coded as:

```
<sec id="sec_5">
  <label>5</label>
  <title>Notation</title>
  <sec id="sec_5.1">
    <label>5.1</label>
    <p>This Recommendation | International Standard references the notation defined by
<std std-id="iso:std:iso-iec:8824:-1" type="undated"><std-ref>ITU-T Rec. X.680</std-ref> |
<std-ref>ISO/IEC 8824-1</std-ref></std>, <std std-id="iso:std:iso-iec:8824:-3"
type="undated"><std-ref>ITU-T Rec. X.682</std-ref> | <std-ref>ISO/IEC 8824-3</std-ref></std>,
W3C XML 1.0 and W3C XML Schema.</p>
  </sec>
  <sec id="sec_5.2">
    <label>5.2</label>
    <p>When it is necessary in the body of this Recommendation | International Standard
to specify, either formally or in examples, the assignment of XER encoding instructions, the
type prefix notation is generally used (but see <xref ref-type="sec" rid="sec_6.3">6.3</xref>
and <xref ref-type="sec" rid="sec_6.4">6.4</xref>). In <xref ref-type="app" rid="sec_A">Annex
A</xref>, an XER encoding control section is used.</p>
  </sec>
  <sec id="sec_5.3">
    <label>5.3</label>
    <p>In this Recommendation | International Standard, <styled-content style="font-
weight: bold; font-family: courier, monospace">bold courier</styled-content> is used for ASN.1
notation and <styled-content style="font-weight: bold; font-family: Arial, sans-serif">bold
Arial</styled-content> is used for XSD notation and for XSD terms and concepts.</p>
  </sec>
  <sec id="sec_5.4">
    <label>5.4</label>
    <p>The XSD Schemas used in the examples in this Recommendation | International
Standard use the prefix <styled-content style="font-weight: bold; font-family: Arial, sans-
serif">xsd:</styled-content> to identify the XSD namespace.</p>
  </sec>
</sec>
```

A `<sec>` usually has a label and title.

ISO

Exceptions can occur in amendments. Sections in amendments without an identifiable label and title should provide at least an empty `<label/>` or `<title/>`.

For example:

```
<sec id="sec_0">
<label/>
<p><b>6. Personal health device DIM</b></p>
<p><b>6.3 Personal health object class definitions</b></p>
...
```

IEC

Sections in corrigenda and amendments have their own label and title.

For example:

```
<sec id="sec-201.7.6.101">
<label>201.7.6.101</label>
<title>*&#160;Additional symbols</title>
<p id="p-18"><i>Addition:</i></p>
<p id="p-19">Symbols for <sc>LENS REMOVAL</sc> and <sc>VITRECTOMY</sc>.</p>
<p id="p-20">If symbols for <sc>LENS REMOVAL</sc> and <sc>VITRECTOMY</sc> devices that
have functions such as <sc>DIATHERMY</sc>, <sc>FRAGMENTATION, LIQUEFACTION FRAGMENTATION,
VITRECTOMY</sc>, and illumination are used, they shall be based on the recommended symbols
of Annex&#160;D and be on the device or near the connection point of the
function.</p></sec></sec>
<sec>
```

4.3.3 Types of clause

Certain clause titles indicate a specific type of clause which should be reflected in the `@sec-type` of the `<sec>`, respectively in the `@content-type` in the back matter.

Values used in IEC/ISO documents for `@sec-type`:

- in `<front>`: *foreword, intro*
- in `<body>`: *scope, norm-refs, terms*

Values used in IEC/ISO documents for `@content-type`:

- in `<back>`: information on whether the annex is informative or normative; *bibl, index*

For example:

1 Scope

These guidelines cover the development, implementation, maintenance, and improvement of strategies and systems for training that affect the quality of the products supplied by an organization.

is coded as:



```

<sec id="sec_1" sec-type="scope">
  <label>1</label>
  <title>Scope</title>
  <p>These guidelines cover the development implementation, maintenance, and improvement of
strategies and systems for training that affect the quality of the products supplied by an
organization.</p>
</sec>

```

The following table lists the major clauses that are normally present in a document, how they are usually numbered and titled, and how they should be identified by the @sec-type of the <sec>:

Section	English Title	French Title	Spanish Title	Russian Title	sec-type attribute
Unnumbered <sec> in <front>	Foreword	Avant-propos	Prólogo / Prólogo de la versión en español	Предисловие	foreword
<sec> optionally numbered 0 in <front>	Introduction	Introduction	Introducción	Введение	intro
<sec> numbered 1 in <body>	Scope	Domaine d'application	Objeto y campo de aplicación	Область применения	scope
<sec> numbered 2 in <body>	Normative references	Références normatives	Referencias normativas	Нормативные ссылки	norm-refs
<sec> numbered 3 in <body>	Terms and definitions / Terms, definitions, ...	Termes et définitions / Termes, définitions, ...	Términos y definiciones	Термины и определения	terms
	Note: title may vary				

Scope

Attributes

@sec-type="scope"

ISO @id="sec_scope"
IEC @id="sec-scope"

For example:

Mechanical vibration and shock — Evaluation of human exposure to whole-body vibration —

Part 1: General requirements

1 Scope

This part of ISO 2631 defines methods for the measurement of periodic, random and transient whole-body vibration. It indicates the principal factors that combine to determine the degree to which a vibration exposure will be acceptable. Informative annexes indicate current opinion and provide guidance on the possible effects of vibration on health, comfort and perception and motion sickness. The frequency range considered is

- 0,5 Hz to 80 Hz for health, comfort and perception, and
- 0,1 Hz to 0,5 Hz for motion sickness.

Although the potential effects on human performance are not covered, most of the guidance on whole-body vibration measurement also applies to this area. This part of ISO 2631 also defines the principles of preferred methods of mounting transducers for determining human exposure. It does not apply to the evaluation of extreme-magnitude single shocks such as occur in vehicle accidents.

This part of ISO 2631 is applicable to motions transmitted to the human body as a whole through the supporting surfaces: the feet of a standing person, the buttocks, back and feet of a seated person or the supporting area of a recumbent person. This type of vibration is found in vehicles, in machinery, in buildings and in the vicinity of working machinery.

is coded as:

```
<sec id="sec_1" sec-type="scope">
  <label>1</label><title>Scope</title>
  <p>This part of <std>ISO 2631</std> defines methods for the measurement of periodic,
random...considered is</p>
  <list list-type="bullet">
    <list-item><label>-</label><p>0,5 Hz to 80 Hz for health, comfort and perception,
and</p></list-item>
    <list-item><label>-</label><p>0,1 Hz to 0,5 Hz for motion sickness.</p></list-item>
  </list>
  <p>Although the potential effects on human performance... in vehicle accidents.</p>
  <p>This part of <std>ISO 2631</std> is applicable to...working machinery.</p>
</sec>
```

Normative References

Editorial note

The Normative References clause is usually required and should be numbered 2, but there are a few exceptions to this rule.

If there are no normative references, the ISO/IEC Directives state that the section should still contain a paragraph to that effect (i.e. stating that there are no normative references for that particular document).

Attributes of <sec>

@sec-type="norm-refs"

@id contains the section number (e.g. "sec_2" for ISO / "sec-2" for IEC)



References to standards

Normative references are coded as a **<ref-list>** with each reference as a **<ref>** containing a **<std>**.

For example:

2 Normative references

The following standards contain provisions which, through reference in this text, constitute provisions of this part of ISO 2631. At the time of publication, the editions indicated were valid. All standards are subject to revision, and parties to agreements based on this part of ISO 2631 are encouraged to investigate the possibility of applying the most recent editions of the standards indicated below. Members of IEC and ISO maintain registers of currently valid International Standards.

ISO 2041:1990, *Vibration and shock — Vocabulary.*

ISO 5805:1997, *Mechanical vibration and shock — Human exposure — Vocabulary.*

ISO 8041:1990, *Human response to vibration — Measuring instrumentation.*

IEC 1260:1995, *Electroacoustics — Octave-band and fractional-octave-band filters.*

is coded as:

```
<sec id="sec_2" sec-type="norm-refs">
  <label>2</label><title>Normative references</title>
  <p>The following standards contain provisions... International Standards.</p>
  <ref-list content-type="norm-refs">
    <ref><std><std-ref>ISO 2041:1990</std-ref>, <title>Vibration and shock –
    Vocabulary.</title></std></ref>
    <ref><std><std-ref>ISO 5805:1997</std-ref>, <title>Mechanical vibration and shock –
    Human exposure – Vocabulary.</title></std></ref>
    <ref><std><std-ref>ISO 8041:1990</std-ref>, <title>Human response to vibration –
    Measuring instrumentation</title></std></ref>
    <ref><std><std-ref>ISO 1260:1995</std-ref>, <title>Electroacoustics – Octave-band and
    fractional-octave-band filters</title></std></ref>
  </ref-list>
</sec>
```

If a reference has a recognizable designator such as [1] (more commonly used in the bibliography section) then this is coded as a **<label>** within the **<ref>**.

References that are not standards

A reference in the normative reference section that is not a standard is coded as it appears (including formatting) using **<mixed-citation>**.

Case 1:

- W3C XML 1.0:2000, *Extensible Markup Language (XML) 1.0 (Second Edition)*, W3C Recommendation, Copyright © [6 October 2000] World Wide Web Consortium, (Massachusetts Institute of Technology, Institut National de Recherche en Informatique et en Automatique, Keio University), <http://www.w3.org/TR/2000/REC-xml-20001006>.

is coded as:

```

<ref>
  <label>--</label>
  <mixed-citation>W3C XML&#x00A0;1.0:2000, Extensible Markup Language (XML)&#x00A0;1.0
  (Second Edition), W3C Recommendation. Copyright [6 October&#x00A0;2000] World Wide Web
  Consortium, (Massachusetts Institute of Technology, Institut National de Recherche en
  Informatique et en Automatique, Keio University), <uri
  xmlns:xlink="http://www.w3.org/1999/xlink">http://www.w3.org/TR/2000/REC-xml-
  20001006</uri>.</mixed-citation>
</ref>

```

Case 2:

- W3C XML Schema:2001, *XML Schema Part 2: Datatypes*, W3C Recommendation, Copyright © [2 May 2001] World Wide Web Consortium, (Massachusetts Institute of Technology, Institut National de Recherche en Informatique et en Automatique, Keio University), <http://www.w3.org/TR/2001/REC-xmlschema-2-20010502>.
- NOTE – When the reference "W3C XML Schema" is used in this Recommendation | International Standard, it refers to W3C XML Schema Part 1 and W3C XML Schema Part 2.
- IETF RFC 2396 (1998), *Uniform Resource Identifiers (URI): Generic Syntax*.
- IETF RFC 1766 (1995), *Tags for the Identification of Languages*.

is coded as:

```

<ref>
  <label>--</label>
  <mixed-citation>W3C XML Schema:2001, XML Schema Part&#x00A0;2: Datatypes, W3C
  Recommendation. Copyright [2 May&#x00A0;2001] World Wide Web Consortium.
  (Massachusetts Institute of Technology, Institut National de Recherche en Informatique et en
  Automatique, Keio University), <uri
  xmlns:xlink="http://www.w3.org/1999/xlink">http://www.w3.org/TR/2001/REC-xmlschema-2-
  20010502<\uri>.</mixed-citation>
  <non-normative-note>
    <label>NOTE</label>
    <p>When the reference "W3C XML Schema" is used in this Recommendation | International
    Standard, it refers to W3C XML Schema Part&#x00A0;1 and W3C XML Schema Part&#x00A0;2.</p>
  </non-normative-note>
</ref>
<ref>
  <label>--</label>
  <std><std-ref>IETF RFC&#x00A0;2396 (1998)</std-ref>, <title>Uniform Resource Identifiers
  (URI): Generic Syntax.</title></std>
</ref>

```

Terms and definitions

Editorial note

The terms and definitions clause is an optional clause in a standard. Its title may vary but will normally contain the words "Terms" and "Definitions".

Attributes of <sec>

@sec-type="terms"

@id contains the section number (e.g. "sec_3" for ISO / "sec-3" for IEC)

Subclauses to the Terms and definitions (e.g. to group terms, or subclauses containing abbreviations or symbols) are coded as any other clause. See 9 for more detailed coding of this section.



Numbered paragraphs

Editorial note

Numbered paragraphs are essentially sections without a title, where the text follows the label directly.

Numbered paragraphs are tagged as sections without a title.

For example this:

```
7.5.3.1 Documented information required by the quality management system and
Standard shall be controlled to ensure:

a) it is available and suitable for use, where and when it is needed;
b) it is adequately protected (e.g. from loss of confidentiality, improper use, or lo
```

is coded as:

```
<sec id="sec_7.5.3">
<label>7.5.3</label><title>Control of documented information</title>
<sec id="sec_7.5.3.1"><label>7.5.3.1</label>
<p>Documented information required by the quality management system and by this International
Standard shall be controlled to ensure:</p>
<list list-type="alpha-lower">
<list-item><label>a</label><p>it is available and suitable for use, where and when it is
needed;</p></list-item>
<list-item><label>b</label><p>it is adequately protected (e.g. from loss of confidentiality,
improper use, or loss of integrity).</p></list-item></list>
</sec>
<sec id="sec_7.5.3.2"><label>7.5.3.2</label>
<p>For the control of documented information, the organization shall address the following
activities, as applicable:</p>
```

4.4 Back matter

4.4.1 General

The back matter is optional and tagged as **<back>**. It can contain annexes, a bibliography, indexes and / or, in IEC legacy documents, footnotes.

4.4.2 Annexes

All annexes are coded as **<app>** within an **<app-group>**.

The word "Annex" and the annex number are coded using **<label>** (excluding any trailing dash), and the title using **<title>**.

Attributes of **<app>**

@id="sec_A" at ISO / *"anx-A"* at IEC

@content-type – see explanations below

Content type – informative and normative annexes

- a) Usually the bracketed text that follows the “Annex” label mentions whether the annex is informative or normative. This information is coded with *@content-type*.

ISO

```
<app-group>
  <app content-type="inform-annex" id="sec_A">
    <label>Annex A</label><annex-type>(informative)</annex-type><title>Types of
    proficiency testing schemes</title>
```

Values of *@content-type*: *inform-annex / normative-annex*

This coding duplicates information between *@content-type* and **<annex-type>**, but allows flexibility when rendering or extracting data.

IEC

The annex type (informative / normative) is not coded as text but will be derived from *@content-type* on rendering.

Going forward, values of *@content-type* will be *informative / normative*

Legacy tagging:

```
<app content-type="inform" id="anx-A">
  <label>Annex A</label>
  <title>Guidance for permissible degradation</title>
```

Values of *@content-type*: *inform / norm*

Under investigation for future implementation:

Values of *@content-type* will be aligned between ISO and IEC and will be updated to: *informative / normative*.

(The annex type at IEC, however, will still be derived from *@content-type*.)

- b) When there is no indication of "informative" or "normative" in the line following the annex title, the bracketed text is coded as follows:

For example:

Annex C

Illustration of real value encoding

(This annex does not form an integral part of this Recommendation | International Standard)

is coded as:



```

<app id="sec_C">
  <label>Annex C</label>
  <title>Illustration of real value encoding<br/><styled-content style-
type="normal">(This annex does not form an integral part of this Recommendation |
International Standard)</styled-content></title>
</app>

```

Clauses inside annexes

Clauses inside an annex (A.1, A.1.2 etc.) tagged as <sec>. (For a more detailed description of <sec> in general, see 4.3.2.)

Their <label> and @id should inherit the label prefix of the parent annex, e.g. A.1, A.2, A.3.

For example:

Annex A
(informative)

Consolidating facility-level data to the organization level

A.1 General

In developing its GHG quantification and reporting system, an organization should ensure that the data system is capable of meeting a range of reporting requirements. GHG data should be recorded and quantified by source, sink and type at least to the facility level. Such data should be retained in its disaggregated form to provide maximum flexibility in meeting a range of reporting requirements. Consolidation of the information can then be carried out as required.

is coded as:

```

<back>
  <app-group>
    <app content-type="inform-annex" id="sec_A">
      <label>Annex A</label>
      <annex-type>(informative)</annex-type>
      <title>Consolidating facility-level data to the organization level</title>
      <sec id="sec_A.1">
        <label>A.1</label>
        <title>General</title>
        <p>In developing its GHG quantification and reporting system, an organization
should ensure that the data system is capable of meeting a range of reporting requirements.
GHG data should be recorded and quantified by source, sink and type at least to the facility
level. Such data should be retained in its disaggregated form to provide maximum flexibility
in meeting a range of reporting requirements. Consolidation of the information can then be
carried out as required.</p>
        .....
      </sec>
    </app>
  </app-group>

```

4.4.3 Bibliography

The bibliography is mostly the last element in the document back matter. It is coded using a <ref-list>.



Attributes of <ref-list>

@content-type="bibl"

@id="sec_bibl" at ISO / "sec-bibliography" at IEC

References inside the bibliography are tagged as <ref>. They can contain a <label> followed by <std> (for standards documents) or <mixed-citation> for other documents.

Attributes of <ref> inside a bibliography

ISO @id="biblref_[value of label]"
IEC @id="bib-[value of label]" if a label exists; else: "bib-[sequential number of the reference in the list]"

For example:

Bibliography	
[1]	ISO Guide 73:2009, <i>Risk management — Vocabulary</i>
[2]	ISO/IEC 31010, <i>Risk management — Risk assessment techniques</i>

is coded as:

```

<ref-list content-type="bibl" id="sec_bibl">
  <title>Bibliography</title>
  <ref id="biblref_1">
    <label>[1]</label>
    <std><std-ref>ISO Guide 73:2009</std-ref>, <title>Risk management -
Vocabulary</title></std>
  </ref>
  <ref id="biblref_2">
    <label>[2]</label>
    <std><std-ref>ISO/IEC 31010</std-ref>, <title>Risk management - Risk assessment
techniques</title></std>
  </ref>
</ref-list>

```

Author names and other information in a reference

For <mixed-citation> references, only the visual presentation should be replicated. Author names and other details are not coded at any level of granularity, all the information is within <mixed-citation>.

For example:

Bibliography

- [1] ISO 2631-2:1989, *Evaluation of human exposure to whole-body vibration — Part 2: Continuous and shock-induced vibration in buildings (1 to 80 Hz)*.
- [2] ISO 10326-1:1992, *Mechanical vibration — Laboratory method for evaluating vehicle seat vibration — Part 1: Basic requirements*.
- [3] ALEXANDER S.J., COTZIN M., KLEE J.B., WENDT G.R. Studies of motion sickness: XVI; The effects upon sickness rates of waves and various frequencies but identical acceleration. *Journal of Experimental Psychology*, **37**, 1947, pp.440-447.

is coded as:

```
<ref-list content-type="bibl" id="sec_bibl">
  <title>Bibliography</title>
  <ref id="biblref_1"><label>[1]</label><std><std-ref>ISO 2631-2:1989</std-ref>,
  <title>Evaluation of human exposure to whole-body vibration – Part 2: Continuous and shock-
  induced vibration in buildings (1 to 80 Hz)</title></std></ref>
  <ref id="biblref_2"><label>[2]</label><std><std-ref>ISO 10326-1:1992</std-ref>,
  <title>Mechanical vibration – Laboratory method for evaluating vehicle seat vibration – Part
  1: Basic requirements</title> .</std></ref>
  <ref id="biblref_3"><label>[3]</label><mixed-citation
  xlink:type="simple">A<sc>lexander</sc> S.J., C<sc>otzin</sc> M., K<sc>lee</sc> J.B.,
  W<sc>endt</sc> G.R. Studies of motion sickness: XVI; The effects upon sickness rates of
  waves and various frequencies but identical acceleration. <italic>Journal of Experimental
  Psychology</italic>, <b>37</b>, 1947, pp.440-447.</mixed-citation></ref>
</ref-list>
```

Line breaks and web addresses inside <mixed-citation>

If there are line breaks or lists within a <mixed-citation>, this can be coded using <break/> inside <mixed-citation>.

Use <uri> for web addresses in references.

For example:

- [22] *ISO Management Systems* ⁴⁾
- [23] Reference web sites:
<http://www.iso.org>
<http://www.tc176.org>
<http://www.iso.org/tc176/sc2>
<http://www.iso.org/tc176/ISO9001AuditingPracticesGroup>



is coded as:

```
<ref id="biblref_22">
  <label>[22]</label>
  <mixed-citation xlink:type="simple"><italic>ISO Management Systems</italic><xref
ref-type="fn" rid="fn_27"><sup>4</sup></xref></mixed-citation>
</ref>
<ref id="biblref_23">
  <label>[23]</label>
  <mixed-citation xlink:type="simple">Reference web sites:<br/><uri
xlink:type="simple">http://www.iso.org</uri><br/><uri
xlink:type="simple">http://www.tc176.org</uri><br/><uri
xlink:type="simple">http://www.iso.org/tc176/sc2</uri><br/><uri
xlink:type="simple">http://www.iso.org/tc176/ISO9001AuditingPracticesGroup</uri></mixed-
citation>
</ref>
```

Multiple lists inside bibliography (numbering continued)

Bibliography

ISO publications related to statistical techniques

[1] ISO 2602:1980, *Statistical interpretation of test results — Estimation of the mean — Confidence interval*

[2] ISO 2854:1976, *Statistical interpretation of data — Techniques of estimation and tests relating to means and variances*

IEC publications related to reliability analysis

[50] IEC 60050-191:1990, *International Electrotechnical Vocabulary — Chapter 191: Dependability and quality of service*

[51] IEC 60300-1:1993, *Dependability management — Part 1: Dependability programme management*

is coded as:

```
<ref-list content-type="bibl" id="sec_bibl">
  <title>Bibliography</title>
  <ref-list content-type="bibl">
    <title>ISO publications related to statistical techniques</title>
    <ref id="biblref_1"><label>[1]</label><std><std-ref>ISO 2602:1980</std-ref>,
    <title>Statistical interpretation of test results – Estimation of the mean – Confidence
interval</title></std></ref>
    <ref id="biblref_2"><label>[2]</label><std><std-ref>ISO 2854:1976</std-ref>,
    <title>Statistical interpretation of data – Techniques of estimation and tests relating to
means and variances</title></std></ref>
  </ref-list>
  <ref-list content-type="bibl">
    <title>IEC publications related to reliability analysis</title>
    <ref id="biblref_50"><label>[50]</label><std><std-ref>IEC 60050-191:1990</std-ref>,
    <title>International Electrotechnical Vocabulary – Chapter 191: Dependability and quality
of service</title></std></ref>
    <ref id="biblref_51"><label>[51]</label><std><std-ref>IEC 60300-1:1993</std-ref>,
    <title>Dependability management – Part 1: Dependability programme
management</title></std></ref>
    .....
  </ref-list>
</ref-list>
```

Multiple lists inside bibliography (numbering restarted)

The *@id* for each reference needs to be unique, whatever system is used for the numbering of the reference label.

Bibliography	
ISO standards	
[1]	ISO 2602:1980, <i>Statistical interpretation of test results — Estimation of the mean — Confidence interval</i>
[2]	ISO 2854:1976, <i>Statistical interpretation of data — Techniques of estimation and tests relating to means and variances</i>
Other publications	
[1]	ISO 9000:2000, <i>Quality management systems — Fundamentals and vocabulary</i>
[2]	GUM:1993, <i>Guide to the expression of uncertainty in measurement</i> . BIPM, IEC, IFCC, ISO, IUPAC, IUPAP and OIML

is coded as:

```
<ref-list content-type="bibl" id="sec_bibl">
  <title>Bibliography</title>
  <ref-list>
    <title>ISO standards</title>
    <ref id="biblref_1_1"><label>[1]</label>...</ref>
    <ref id="biblref_1_2"><label>[2]</label>...</ref>
  </ref-list>
  <ref-list>
    <title>Other Publications</title>
    <ref id="biblref_1_3"><label>[1]</label>...</ref>
    <ref id="biblref_1_4"><label>[2]</label>...</ref>
  </ref-list>
</ref-list>
```

4.4.4 Index

The index is included in **<back>**, after the bibliography and, in IEC legacy content, before any footnotes. It is coded within **<index>**.

If an index resulting from legacy conversion is present, only references to sections are listed, as page numbers are no longer relevant in XML.

For example:

Index of definitions			
Terms	IEV	subclause	
A			
ambient air temperature	----- 441-11-13, MOD	3.8.9	[df 1]
angle of overlap μ	-----551-16-05	3.5.5	[df 2]
(auxiliary) arm	-----551-15-05	3.2.3	[df 3]
(principal) arm	-----551-15-02	3.2.2	[df 4]

is coded as:

```

<index id="sec-index">
<index-title-group>
<title>Index of definitions</title></index-title-group>
<index-div>
<index-title-group>
<title>A</title></index-title-group>
<index-entry id="df-1">
<term>ambient air temperature</term>
<see-entry><related-object document-id="urn:iec:std:iec:60050-441:::#con-441.11.13" document-id-
type="uri"><std content-type="uri" std-id="urn:iec:std:iec:60050-441:::#con-441.11.13"><std-
ref>441&#8209;11&#8209;13, MOD</std-ref></std></related-object></see-entry>
<see-entry>3.8.9</see-entry>
<see-entry>df 1</see-entry></index-entry>
<index-entry id="df-2">
<term>angle of overlap <italic>&#956;</italic></term>
<see-entry><related-object document-id="urn:iec:std:iec:60050-551:::#con-551.16.05" document-id-
type="uri"><std content-type="uri" std-id="urn:iec:std:iec:60050-551:::#con-551.16.05"><std-
ref>551&#8209;16&#8209;05</std-ref></std></related-object></see-entry>
<see-entry>3.5.5</see-entry>
<see-entry>df 2</see-entry></index-entry>
<index-entry id="df-3">
<term>(auxiliary) arm</term>
<see-entry><related-object document-id="urn:iec:std:iec:60050-551:::#con-551.15.05" document-id-
type="uri"><std content-type="uri" std-id="urn:iec:std:iec:60050-551:::#con-551.15.05"><std-
ref>551&#8209;15&#8209;05</std-ref></std></related-object></see-entry>
<see-entry>3.2.3</see-entry>
<see-entry>df 3</see-entry></index-entry>
<index-entry id="df-4">
<term>(principal) arm</term>
<see-entry><related-object document-id="urn:iec:std:iec:60050-551:::#con-551.15.02" document-id-
type="uri"><std content-type="uri" std-id="urn:iec:std:iec:60050-551:::#con-551.15.02"><std-
ref>551&#8209;15&#8209;02</std-ref></std></related-object></see-entry>
<see-entry>3.2.2</see-entry>
<see-entry>df 4</see-entry></index-entry>
...

```

4.4.5 Footnotes

IEC

Legacy tagging

In IEC legacy publications, footnotes are coded as the last element inside the **<back>** element.

More information on footnotes can be found in 4.4.5.



5 Content

5.1 Spaces, punctuation and formatting

Especially in legacy publications, there will be elements such as spaces, tabs and line breaks, that serve formatting purposes. These should be replaced wherever possible or deleted if they are not necessary during the conversion to XML, unless they are significant, such as in formulae, tables, and example code.

Sequential spacing characters should be coded as a single space, unless they are significant.

Where spacing characters or tabs have been used to align blocks of text into columns, the text should instead be coded in a table or array (see also 6.3 on the layout of content in a table).

IEC

Legacy tagging

In IEC legacy publications, spaces are maintained in form fields.

Non-breaking spaces can be inserted to prevent automatic line breaks between two text portions. The following are a few patterns where a non-breaking space (or) should be used.

These are usually found when the text follows/precedes numbers or numbering text such as A,B,C... or a,b,c ...

Some examples:

```
[number] [SI Unit]
(Part)[space]([0-9])
([0-9])[space](%)
(ISO)[space]([0-9])
(ISO/TC)[space]([0-9])
(NOTE)[space]([0-9])
(Note)[space]([0-9][space]to entry:)
(Table)[space]([0-9])
(Formula)[space]([\((0-9)*\)])
(SC)[space]([0-9])
(Figure)[space]([0-9])
(Clause)[space]([0-9])
(Volume)[space]([0-9])
```



(Article)[space]([A-Z|a-z][\\.|\\]))

(Step)[space]([0-9])

(OIML)[space](D)

(Annex)[space]([A-Z|a-z][\\.|\\]))

[space](— [A-Z])

[0-9] [mathematical signs]][0-9]

Numbers formatted with spaces, e.g. 1 000: a non-breaking space should be used, e.g. 1 000.

When processing legacy documents, it is recommended that non-standard fonts used for a semantic reason should be preserved. All punctuation characters (except soft hyphens) are to be considered significant and preserved.

Superscript, subscript, italic, bold, underlined, small caps, strike-through, mono-spaced etc. text is coded as it appears using: <sup>, <sub>, <italic>, <bold>, <u>, , <monospace> etc.

<roman> is used as an override for unformatted text inside a different formatting, e.g.:

Cell type	Charge voltage
KX	V 1,425 ± 0,005

will be coded as:

```
<p id="p-152">Charge voltage</p>
<p id="p-153"><roman>V</roman></p></th></tr>
```

Where formatting carries meaning, it is preferable to tag it as <styled-content> (see 5.5). In general, semantic tagging is preferable to formatting tagging.

The element <sc> is used to mark text that should appear in a font that creates smaller capital letters ("small caps"). The letters inside the tag are coded in lowercase. Only the letters which need to be converted to small capitals should be included into the tag.

For example:

```
<p>... Sequence comparisons with programs <sc>gapped blast</sc> and <sc>psi-blast</sc> and 434100 sequences of databases did not find ...</p>
```

5.2 Using <label> and <title>

<label> is used for numbers, symbols or prefix words placed at the beginning of display elements such as formulae, list items or figures. Emphasis elements, such as italic, underline and bold formatting, can be included.

<title> is used for designations of elements such as sections, figures, tables, etc.



At ISO and IEC, labels and section titles are bolded automatically during rendering, but italic and underline formatting are marked up. Examples can be found at the entry for [<label>](#) in the NISO STS tag library. For more specific use of these two elements, please refer to the parent element (e.g. [<figure>](#), [<sec>](#), [<list>](#)) in this document.

5.3 Using `<p>`

General body text should be captured within the `<p>` element.

Attributes

@style-type – to define alignment or formatting

@content-type – to define the type of content, e.g. *dimensions* (see 6.6.4 for usage in tables, 8.4 for usage in figures)

To define the alignment of an entire `<p>`, *@style-type* can be used.

Possible values of *@style-type* in `<p>` are:

- align-left
- align-right
- align-center
- valign-top
- valign-bottom
- valign-middle
- indent

If more than one *@style-type* applies, separate them with a semi colon, e.g. *@style-type="align-center;valign-middle"*.

@style-type can also be used inside `<styled-content>`; for additional values in this context, see 5.5.

5.4 Symbols

Non-alphanumeric symbols should be coded using UTF-8 codepoint.

En- and em-dashes should be preserved as used and coded in UTF-8.

5.5 Formatting text with `<styled-content>`

When text styling is used to convey meaning, this shall be done using `<styled-content>` rather than direct formatting (`<bold>`, `<italic>` etc.).

Attributes

@style-type

@style

5.5.1 *@style-type* / *@specific-use*

These attributes are most often used to mark up additions and deletions in redline documents.

ISO

Values for *@style-type* (in addition to those for alignment mentioned in):

- *addition* (for additions, e.g. in redline versions; rendering will be in green)
- *deletion* (for deletions, e.g. in redline versions; rendering will be in red and strikethrough)

IEC

Values for *@specific-use*:

- *insert* (for additions, e.g. in redline versions; rendering will be in green)
- *delete* (for deletions, e.g. in redline versions; rendering will be in red and strikethrough)

For example:

3.4
rated capacity

~~quantity of electricity C_5 Ah (ampere-hours) declared by the manufacturer which a single cell can deliver when discharged at the reference test current of 0,2 I (ampere) to a final voltage of 1,0 V at +20 °C after charging, storing and discharging under the conditions specified in clause 4~~
capacity value of a cell or battery determined under specified conditions and declared by the manufacturer

is coded as:

```
<term-sec id="con-3.4">
<label>3.4</label>
<tbx:termEntry id="te-3.4">
<tbx:langSet xml:lang="en">
<tbx:definition><styled-content specific-use="delete">quantity of electricity
<italic>C</italic><sub>5</sub>Ah (ampere-hours) declared by the manufacturer which a single cell
can deliver when discharged at the reference test current of 0,2 <italic>I</italic><sub>t</sub>A
to a final voltage of 1,0&#160;V at +20&#160;&#176;C after charging, storing and discharging
under the conditions specified in <xref ref-type="sec" rid="sec-4">clause&#160;4</xref></styled-
content> <styled-content specific-use="insert">capacity value of a cell or battery determined
under specified conditions and declared by the manufacturer</styled-content></tbx:definition>
<tbx:tig>
<tbx:term id="ter-rated_capacity">rated capacity</tbx:term>
<tbx:partOfSpeech value="noun"/>
<tbx:normativeAuthorization value="preferredTerm"/>
<tbx:termType value="fullForm"/></tbx:tig></tbx:langSet></tbx:termEntry></term-sec>
```

Where **<styled-content>** is not admitted, *@specific-use* is used on its own.

For example:

IEC 60038:~~2002~~, *IEC standard voltages*

IEC 60060-1:~~1989~~, *High-voltage test techniques – Part 1: General definitions and test requirements*

IEC 60071-2, *Insulation co-ordination – Part 2: Application guidelines*

IEC 60099-4, *Surge arresters – Part 4: Metal-oxide surge arresters without gaps for a.c. systems*

~~IEC 60507, *Artificial pollution tests on high voltage insulators to be used on a.c. systems*~~

~~IEC 60633, *Terminology for high voltage direct current (HVDC) transmission*~~

is coded as:

```
<ref-list content-type="norm-refs">
<ref><std><std-id std-id-link-type="urn" std-id-
type="dated">urn:iec:std:iec:60038:2002::</std-id><std-ref>IEC&#160;60038</std-ref><styled-
content specific-use="delete">:2002</styled-content><title>IEC standard
voltages</title></std></ref>
<ref><std><std-id std-id-link-type="urn" std-id-type="dated">urn:iec:std:iec:60060-1::::</std-
id><std-ref>IEC&#160;60060-1</std-ref><styled-content specific-use="delete">:1989</styled-
content><title>High-voltage test techniques &#8211; Part&#160;1: General definitions and test
requirements</title></std></ref>
<ref><std><std-id std-id-link-type="urn" std-id-type="undated">urn:iec:std:iec:60071-
2::::</std-id><std-ref>IEC&#160;60071-2</std-ref><title>Insulation co-ordination &#8211;
Part&#160;2: Application guide</title><styled-content specific-use="insert">lines</styled-
content></std></ref>
<ref><std><std-id std-id-link-type="urn" std-id-type="undated">urn:iec:std:iec:60099-
4::::</std-id><std-ref>IEC&#160;60099-4</std-ref><title>Surge arresters &#8211; Part&#160;4:
Metal-oxide surge arresters without gaps for a.c. systems</title></std></ref>
<ref specific-use="delete"><std><std-id std-id-link-type="urn" std-id-
type="undated">urn:iec:std:iec:60507::::</std-id><std-ref>IEC 60507</std-ref><title>Artificial
pollution tests on high-voltage insulators to be used on a.c. systems</title></std></ref>
<ref specific-use="delete"><std><std-id std-id-link-type="urn" std-id-
type="undated">urn:iec:std:iec:60633::::</std-id><std-ref>IEC 60633</std-
ref><title>Terminology for high-voltage direct current (HVDC)
transmission</title></std></ref></ref-list></sec>
```

@style-type is also used with the value “normal” for plain text within a string of text of different style.

For example:

Annex C

Illustration of real value encoding

(This annex does not form an integral part of this Recommendation | International Standard)

is coded as:

```
<app id="sec_C">
  <label>Annex C</label>
  <title>Illustration of real value encoding<br/><styled-content style-type="normal">(This annex does not form an integral part of this Recommendation | International Standard)</styled-content></title>
</app>
```

5.5.2 @style

For standards organizations that want to keep a number of named styles consistent throughout the document (e.g. for use by CSS), the use of `@style` with a predefined list of values is possible.

Legacy tagging

Generally, using specific fonts is discouraged in XML. However, in legacy content where the document explicitly states that certain fonts should be used, `<styled-content>` with `@style` should be used as shown below:

5.3 In this Recommendation | International Standard, **bold Courier** is used for ASN.1 notation and **bold Arial** is used for XSD notation and for XSD terms and concepts.

is coded as:

```
<sec id="iso-iec_8825-5_2008_en_sec_5.2">
  <label>5.3</label>
  <title />
  <p>In this Recommendation | International Standard, <styled-content style="font-weight: bold; font-family: Courier, monospace">bold Courier</styled-content> is used for ASN, 1 notation and <styled-content style="font-weight: bold; font-family: Arial, sans-serif">bold Arial</styled-content> is used for XSD notation and for XSD terms and concept.</p>
</sec>
```

5.6 Notes and examples

Editorial note

Notes are prefixed by the word NOTE (followed by a number where there is more than one sequential note in a clause).

Examples are prefixed by the word EXAMPLE (followed by a number where there is more than one sequential example in a clause).

Notes and examples in regular text are tagged as `<non-normative-note>` and `<non-normative-example>` respectively.

Notes and examples inside terminological entries are coded using TBX according to the coding instructions for terms and definitions (see 9.3.4, *Examples in terminology* Notes in terminology, or 9.3.5, *Notes in terminology*).

For notes inside tables, figures and formulae, see 5.6.1 below.

The designation text, such as NOTE or EXAMPLE, including any existing sequential number or punctuation, should be captured in a `<label>`, retaining the capitalisation (and excluding any space between the label and the following text).

The note text is to be coded with the usual elements used within <sec>, e.g. <p>, <list> etc..

For example:

Case 1 – note with additional punctuation:

This Recommendation | International Standard specifies the final XER encoding instructions that are to be applied as part of the defined mapping to ASN.1 types, but does not specify which syntactic form is to be used for the specification of those final XER encoding instructions, or the order or manner of their assignment.

NOTE – Implementers of tools generating these mappings may choose any syntactic form or order of assignment that results in the specified final XER encoding instructions being applied. Examples in this Recommendation | International Standard generally use the type prefix form, but use of an XER Encoding Control Section may be preferred for the mapping of a complete XSD Schema, as a matter of style.

There are different ways (syntactically) of assigning XER encoding instructions for use in EXTENDED-XER encodings (for example, use of ASN.1 type prefix encoding instructions or use of an XER encoding control section). The choice of these syntactic forms is a matter of style and is outside the scope of this Recommendation | International Standard.

is coded as:

```
<non-normative-note>
  <label>NOTE -</label>
  <p>Implementers of tools generating these mappings may choose any syntactic form or order
of...<p>
</non-normative-note>
```

Case 2 – two notes in the form of a list:

9.2.3 Frequency weighting

A single frequency weighting, W_f , is recommended for the evaluation of the effects of vibration on the incidence of motion sickness.

NOTES

- 1 It is recommended that additional information about the motion conditions also be reported. This should include the frequency composition, duration and directions of motions.
- 2 There is some evidence that motions having similar frequencies and r.m.s. accelerations but different waveforms may have different effects.

is coded as:

```
<non-normative-note>
  <label>NOTES</label>
  <list list-type="order">
    <list-item><label>1</label><p>It is recommended...</p></list-item>
    <list-item><label>2</label><p>There is some...</p></list-item>
  </list>
</non-normative-note>
```

Case 3 – two notes on separate lines:

NOTE 1	This is a note
NOTE 2	This is another note

is coded as:

```

<non-normative-note>
  <label>NOTE 1</label>
  <p>This is a note</p>
</non-normative-note>
<non-normative-note>
  <label>NOTE 2</label>
  <p>This is another note</p>
</non-normative-note>

```

Case 4 - example:

EXAMPLE	This is an example
---------	--------------------

is coded as:

```

<non-normative-example>
  <label>EXAMPLE</label>
  <p>This is an example</p>
</non-normative-example>

```

5.6.1 Notes in tables, figures and formulae

Notes may be associated with tables, figures or formulae, where they appear between the table, graphic or formula and its designation. In these cases, the note is coded as **<non-normative-note>** within **<fig>**, **<table-wrap>** or **<disp-formula>**.

Table notes are tagged inside **<table-wrap-foot>**.

For example:

aspect_ratio_idc	Sample aspect ratio	(informative) Examples of use
0	Unspecified	
1	1:1 ("square")	1280x720 16:9 frame without horizontal overscan 1920x1080 16:9 frame without horizontal overscan (cropped from 1920x1088) 640x480 4:3 frame without horizontal overscan
2	12:11	720x576 4:3 frame with horizontal overscan 352x288 4:3 frame without horizontal overscan

NOTE 1 – For the examples in Table E-1, the term "without horizontal overscan" refers to display processes in which the display area matches the area of the cropped decoded pictures and the term "with horizontal overscan" refers to display processes in which some parts near the left and/or right border of the cropped decoded pictures are not visible in the display area. As an example, the entry "720x576 4:3 frame with horizontal overscan" for aspect_ratio_idc equal to 2 refers to having an area of 704x576 luma samples (which has an aspect ratio of 4:3) of the cropped decoded frame (720x576 luma samples) that is visible in the display area.

is coded as:

```

<table-wrap id="tab_E-1">
  <label>Table E-1</label><caption><title>Meaning of sample aspect ratio
indicator</title></caption>
  <table border="1" frame="box" rules="all">
    <colgroup>
      ...
    </colgroup>
    <thead>
      <tr>
        <th>aspect...</th>
        ...
      </tr>
    </thead>
    <tbody>
      <tr>
        <td>0...</td>
        ...
      </tr>
      ...
    </tbody>
  </table>
  <table-wrap-foot>
    <non-normative-note><label>NOTE 1 -</label><p>For examples in...</p></non-normative-
note>
  </table-wrap-foot>
</table-wrap>

```

5.6.2 Notes with label “Warning / Important / Caution”

For content with a label such as “Warning / Important / Caution”, a note is used with *@content-type=“warning”* or *“important”* or *“caution”* respectively.

5.7 Lists

Lists are coded using **<list>**, with each list item tagged as **<list-item>**.

Attributes of <list>

@id

@list-type

Values and usage of *@list-type*:

ISO	
value	usage
simple	there is no prefix character before each item
bullet	the prefix character is a bullet
dash	the prefix character is a dash*
alpha-lower	the prefix character is a lowercase alphabetical character: a, b, c ...
alpha-upper	the prefix character is an uppercase alphabetical character: A, B, C ...
roman-lower	the prefix character is a lowercase roman numeral: i, ii, iii, iv ...
roman-upper	the prefix character is an uppercase roman numeral: I, II, III, IV ...

order	any other ordered list: 1, 2, 3 ...
* ISO generally only uses the em-dash for unnumbered and unordered list items.	
IEC	
value	usage
simple	there is no prefix character before each item
bullet	the prefix character is a bullet
dash	the prefix character is a dash
symbol	the prefix character is a symbol (possible if the symbol has semantic meaning but discouraged): ► ■ ◎ etc.
arabic	ordered list with arabic numerals as prefix: 1, 2, 3, ...
alpha-lower	ordered list with lowercase alphabetical prefix characters: a, b, c ...
alpha-upper	ordered list with uppercase alphabetical prefix characters: A, B, C ...
roman-lower	ordered list with lowercase roman numerals as prefix: i, ii, iii, iv ...
roman-upper	ordered list with uppercase roman numerals as prefix: I, II, III, IV ...
order	any other ordered list, e.g. "Step I, Step II..." or "Error 1, Error 2" etc.
other	- lists with non-sequential numbering (e.g. with item 1 followed by item 3) - lists starting with a number or character other than "1", "I", "i", "A" or "a"
Under investigation for future implementation:	
The long-term goal is to provide list tagging which allows to render the required prefix automatically from the value in <i>@list-type</i> , without having to capture the <label> for each list item. In an online authoring environment, these labels will also be attributed to the whole list (unless exceptions are specified).	

All lists are coded outside the preceding **<p>**.

For example:

<p>13.3 Reasons for differences</p> <p>There may be a variety of reasons for a significant difference between combined uncertainty estimates. These include the following:</p> <ul style="list-style-type: none"> — genuine differences in performance between laboratories; — failure of a model to include all the significant effects on the measurement; — overestimation or underestimation of a significant contribution to uncertainty.
--

is coded as:

```

<sec id="sec 13.3">
  <label>13.3</label>
  <title>Reasons for differences</title>
  <p>There may be a variety of reasons for a...These include the following:</p>
  <list list-type="dash">
    <list-item>
      <label></label>
      <p>genuine differences in performance between laboratories;</p>
    </list-item>
    <list-item>
      <label></label>
      <p>failure of a model to include the significant effects on the measurement;</p>
    </list-item>
    <list-item>
      <label></label>
      <p>overestimation or underestimation of a significant contribution to
uncertainty.</p>
    </list-item>
  </list>

```

5.7.1 Lists with labels (ordered / unordered lists)

In addition to identifying the type of label (bullet or number) used in the list, within each **<list-item>** the actual bullet character or number should be captured in a **<label>**. The text of a list item is tagged inside **<p>**.

For example:

- ```

a) first item in the list
b) second item in the list
c) third item in the list

```

is coded as:

```

<list list-type="alpha lower">
 <list-item>
 <label>a</label>
 <p>first item in the list;</p>
 </list-item>
 <list-item>
 <label>b</label>
 <p>second item in the list</p>
 </list-item>
 <list-item>
 <label>c</label>
 <p>third item in the list</p>
 </list-item>
</list>

```

### 5.7.2 Lists without labels

The following indentation should be maintained by coding it as a list with *@list-type="simple"*.

## Hardware

The hardware type consists of all the physical elements supporting processes.

### Data processing equipment (active)

Automatic information processing equipment including the items required to operate independently.

### Transportable equipment

Portable computer equipment.

Examples: laptop computer, Personal Digital Assistant (PDA).

### Fixed equipment

Computer equipment used on the organization's premises.

Examples: server, microcomputer used as a workstation.

is coded as:

```
<list list-type="simple">
 <list-item>
 <p><u>Hardware</u></p>
 <p>The hardware type consists of all the physical elements supporting processes.</p>
 <list list-type="simple">
 <list-item>
 <p><u>Data processing equipment (active)</u></p>
 <list list-type="simple">
 <list-item>
 <p>Automatic information processing equipment including the items
required to operate independently.</p>
 </list-item>
 </list>
 </list-item>
 <list-item>
 <p><u>Transportable equipment</u></p>
 <list list-type="simple">
 <list-item>
 <p>Portable computer equipment.</p>
 </list-item>
 <list-item>
 <p><non-normative-example><label>Examples</label><p>laptop
computer, Personal Digital Assistant (PDA).</p></non-normative-example></p>
 </list-item>
 </list>
 </list-item>
 <list-item>
 <p><u>Fixed equipment</u></p>
 <list list-type="simple">
 <list-item>
 <p>Computer equipment used on the organization's premises.</p>
 </list-item>
 ...
 </list>
 </list-item>
 </list>
 </list>
```

## 5.8 Specific text alignments

Text that is aligned in columns and without column or row borders is coded using `<array>` containing a `<table>`.



This type of table layout for formatting purposes should not have the various attributes associated with formal tables (no `<table-wrap>`, `<caption>`, `<title>`, `<label>` etc.).

### Attribute of `<array>`

`@id`

### Recommended attribute of `<col>` (inside `<col-group>`)

`@colwidth` to specify the column width (in percent) and preserve visual alignment

For example :

item	this is an item
object	this is an object
thing	this is a thing

is coded as:

```
<array>
 <table>
 <col-group>
 <col align=center col width="15">
 <col align=center col width="30">
 <col align=center col width="45">
 </col-group>
 <tbody>
 <tr><td><td>item</td><td>this is an item</td></tr>
 <tr><td><td>object</td><td>this is an object</td></tr>
 <tr><td><td>thing</td><td>this is a thing</td></tr>
 </tbody>
 </table>
</array>
```

## 5.9 Quotations

A single block of text that is indented (normally an extract or extended quote from another work that is made typographically distinct from the surrounding text) is coded using `<disp-quote>`.

```
<sec>
 <title>Introduction</title>
 <disp-quote>
 <p>Dead flies cause the ointment of the apothecary to send forth a stinking savor; so doth a little folly him that is in reputation for wisdom and honour.</p>
 <attrib>Ecclesiastes 10:1</attrib>
 </disp-quote>
 <p>The term “flies in the ointment” is occasionally used to describe minor defects in some endeavor. But this quote from Ecclesiastes has a much wider scope ...</p>
</sec>
```

## 5.10 Graphics

**Editorial note**

Graphics can exist inside figures (in the sense of structural elements, as defined in the ISO/IEC Directives Part 2), but also independently, either as block elements or as inline graphics.

For information on tagging figures, see 8.

Graphics inside figures or as independent block elements are coded as **<graphic>**.

The name of the graphic file should match the ID of the figure, prefixed by "fig".

**ISO**

For example, fig\_1 for Figure 1.

**IEC**

For example, fig-1 for Figure 1.

Graphics in the same line as the surrounding text are coded as **<inline-graphic>**.

The names of inline graphics and graphics which are not part of figures are prefixed by "img".

**ISO**

For example, *img\_21139-1\_ed1TabfigA1a*.

The filename convention is:

*img\_{standard number}{-standard part number}\_ed{edition number}{image type and number}*

Annex images are denoted by 'A' before the number. Numbering must be sequential throughout the document for its type (i.e. all inline graphics must follow the same naming convention and be sequentially numbered). Image types and numbering used are as follows:

Convention	Type	Example
Tabfig	Table figure	img_ed1Tabfig2 img_ed1Tabfig2a img_ed1TabfigB2
fig	Figure	img_ed2figB12c img_ed1fig5
fig_key	Figure key	img_ed1fig1_key1
fig_{language}	Translated language figures	img_ed1fig1_f img_ed1fig1_e

**IEC**

For example, *img-10.1*

The filename convention is: *img-X-Y*, where X is the page number in the PDF and Y the sequential number of the image on that page.

```
<fig id="fig-4">
<label>Figure 4</label>
<caption>
```

```

<title>Example for a typical test set up for measurement of conducted and/or radiated
disturbances from a floor standing EUT, 3D view</title></caption>
<graphic xlink:href="asset/fig-4"/>
<def-list>
<def-item>
<term id="figk-4-1">
<inline-graphic xlink:href="asset/img-36.1"/></term>
<def>
<p>interconnecting cables</p></def></def-item></def-list></fig>

```

### Attribute of <graphic> and <inline-graphic>

@xlink:href containing the reference to the graphic file, without the file extension (e.g. ".png").

#### ISO

The reference does not contain the name of the asset folder for formal figures.

```
<graphic xlink:href="fig_A.1"/>
```

#### IEC

The reference contains the name of the asset folder.

```
<graphic xlink:href="asset/fig-A.1"/>
```

## 5.11 Boxed text

The heading of the boxed text is coded with <caption><title>.

The rest of the contents of the boxed text is coded using <p>, and do not use any structural elements such as <sec>, but can use the block level elements to deal with tables, figures and graphics.

Below are the block level elements which are ideal to be used inside <boxed-text>.

- array
- boxed-text
- non-normative-note
- non-normative-example
- disp-formula
- disp-quote
- ref-list
- table-wrap
- fig
- graphic
- list

The italicisation should also be defined.



<xref> will not be coded for the contents wrapped with <boxed-text>.

<std> will not be coded for the contents wrapped with <boxed-text>. Only the heading of the boxed text should contain <std> whenever applicable.

<boxed-text> is not used for content with labels such as “Warning / Important / ...” – for these, notes are used (see 5.6.2).

For example:

**5.3 Quality objectives**

The management of the metrological function shall define and establish measurable quality objectives for the measurement management system. Objective performance criteria and procedures for the measurement processes, and their control, shall be defined.

*Guidance*

*Examples of such quality objectives at different organizational levels are as follows:*

- *no nonconforming product is to be accepted nor conforming product rejected due to incorrect measurements;*
- *no measurement process is to be out of control for more than one day without detection;*
- *all metrological confirmations are to be completed by the agreed times.*
- *there are to be no illegible metrological confirmation records;*
- *all of the technical training programmes are to be completed per the established schedule.*
- *the amount of time measuring equipment is out of operation is to be reduced by a stated percentage.*

is coded as:

```

<sec id="sec_5.3">
 <label>5.3</label>
 <title>Quality objectives</title>
 <p>The management of the metrological function shall define and establish measurable
 quality objectives for the measurement management system. Objective performance criteria and
 procedures for the measurement processes, and their control, shall be defined.</p>
 <boxed-text position="anchor">
 <caption><title><i>Guidance</i></title></caption><p><i>Examples of such
 quality objectives at different organizational levels are as follows</i>:</p>
 <list list-type="bullet">
 <list-item>
 <label></label>
 <p><i>no nonconforming product is to be accepted nor conforming product
 rejected due to incorrect measurements;</i></p>
 </list-item>
 <list-item>
 <label></label>
 <p><i>no measurement process is to be out of control for more than one
 day without detection;</i></p>
 </list-item>
 <list-item>
 <label></label>
 <p><i>all metrological confirmations are to be completed by the agreed
 times;</i></p>
 </list-item>
 <list-item>
 <label></label>
 <p><i>there are to be no illegible metrological confirmation
 records;</i></p>
 </list-item>
 <list-item>
 <label></label>
 <p><i>all of the technical training programmes are to be completed per
 the established schedule;</i></p>
 </list-item>
 <list-item>
 <label></label>
 <p><i>the amount of time measuring equipment is out of operation is to be
 reduced by a stated percentage</i>.</p>
 </list-item>
 </list>
 </boxed-text>
</sec>

```

If the text in the box is imported from another standard, that standard is cited in the boxed text, and `@content-type="foreign-source"` is used.

## 5.12 Code

Technical content such as programming language code, pseudo-code, schemas and DTDs or markup fragments should be tagged as `<code>`. Whitespace will be preserved within `<code>`.

Preformatted text, which may contain emphasis elements for syntax coloring, or it may contain an external link to a binary executable file, can be included in `<code>`.

### Attributes of `<code>`

- `@id`
- `@code-type` – typically a descriptive word such as “pseudo-code” or “scripting” that describes the type of language (not the name of the language) in which the code is written.
- `@code-version` – Version of the program code that is shown inside the `<code>` element, for example, “25.1 second patch”





- *@executable* – Indicates whether or not the code snippet to which the attribute is attached is intended for direct execution
- *@language* – Code Language
- *@language-version* – Code Language Version
- *@platforms* – Platform on which the code is intended to run, for example, “Mac OS X”.

Authors are encouraged to make use of these attributes wherever possible and applicable. In ISO and IEC documents, however, these are not used today. They will be in the future.

CDATA should be used to avoid parsing XML examples included in the text.

```
<code> simple_line = (symbol_definition | collating_element |
weight_assignment | order_end)? line_completion ;
table_line = simple_line | tailoring_line ;
tailoring_line = (reorder_after | order_start | reorder_end |
section_definition | reorder_section_after)
line_completion ;
</code>
```

### 5.13 Preformatted text

The **<preformat>** element is typically used for machine-related communication such as ASCII art and error message reports, in which whitespace such as tabs, line feeds, and spaces should be preserved. It should not be used for code (even if some legacy documents have used this in the past).

```
<preformat><![CDATA[
 +-----+
 | | IPsec | |
Protected |Tunnel | tunnel |Tunnel | Protected
Subnet <-->|Endpoint |<----->|Endpoint |<--> Subnet
 | | | |
 +-----+
]]></preformat>
```

### 5.14 Editing instructions (deletions, additions) – IEC only

For instructions on how a given document amends another document (amendments, certain IEC series), **<editing-instruction>** is used. For the tagging of amendments, see also *Annex C*.

For example:

<p><b>201.1.2 Object</b></p> <p><b>Replacement:</b></p> <p>The object of this particular standard is to establish particular BASIC SAFETY requirements for HEARING AIDS and HEARING AID SYSTEMS as defined in 201.3.202 and 201.3.203.</p> <p><b>201.1.3 * Collateral standards</b></p> <p><b>Addition:</b></p> <p>This particular standard refers to those applicable collateral standards that are listed in Clause 2 of the general standard and Clause 201.2 of this particular standard.</p> <p>IEC 60601-1-3, IEC 60601-1-9 and IEC 60601-1-10 do not apply. All other published collateral standards in the IEC 60601-1 series apply as published.</p>
---------------------------------------------------------------------------------------------------------------------------------------------------------------------------------------------------------------------------------------------------------------------------------------------------------------------------------------------------------------------------------------------------------------------------------------------------------------------------------------------------------------------------------------------------------------------------------------------------------------------------------------------------------------

is coded as:

```

<label>201.1.2</label>
<title>Object</title>
<editing-instruction>
<p id="p-66"><italic>Replacement:</italic></p></editing-instruction>
<p id="p-67">The object of this particular standard is to establish particular <sc>basic safety</sc> requirements for <sc>hearing aids</sc> and <sc>hearing aid systems</sc> as defined in <xref ref-type="other" rid="con-201.3.202">201.3.202</xref> and <xref ref-type="other" rid="con-201.3.203">201.3.203</xref>.</p></sec>
<sec id="sec-201.1.3">
<label>201.1.3</label>
<title>* Collateral standards</title>
<editing-instruction>
<p id="p-68"><italic>Addition:</italic></p></editing-instruction>
<p id="p-69">This particular standard refers to those applicable collateral standards that are listed in Clause 2 of the general standard and <xref ref-type="sec" rid="sec-201.2">Clause 201.2</xref> of this particular standard.</p>
<p id="p-70"><std><std-id std-id-link-type="urn" std-id-type="undated">urn:iec:std:iec:60601-1-3:::</std-id><std-ref>IEC 60601‑1‑3</std-ref></std>, <std><std-id std-id-link-type="urn" std-id-type="undated">urn:iec:std:iec:60601-1-9:::</std-id><std-ref>IEC 60601‑1‑9</std-ref></std> and <std><std-id std-id-link-type="urn" std-id-type="undated">urn:iec:std:iec:60601-1-10:::</std-id><std-ref>IEC 60601‑1‑10</std-ref></std> do not apply. All other published collateral standards in the <std><std-id std-id-link-type="urn" std-id-type="undated">urn:iec:std:iec:60601-1::ser::</std-id><std-ref>IEC 60601‑1 series</std-ref></std> apply as published.</p></sec>

```

**Legacy tagging**

Legacy content uses **<editing-instruction>** with *@content-type*; possible values are addition, replacement, deletion, modification. This attribute has been dropped in more recent conversion.

## 6 Tables

### 6.1 General

Tables are coded using XHTML. The NISO STS framework also allows CALS, but this format is not used by ISO or IEC. This document does not explain CALS tagging.

Further detailed information on capturing content within tables is included in .



Nested tables are not permitted.

#### Editorial note

Nested tables may appear in legacy documents, but are deprecated.

Borders and shading should be represented using the style attribute of the respective table element. The width of table columns should be defined using *@width* inside `<col >` within `<table>`.

#### ISO

In ISO, the width of each column is captured as a percentage, but the overall table width is set in `<table>` *@width* in absolute number of pixels.

For example:

```
<table-wrap id="tab_B.1" position="float">
<label>Table B.1</label>
<caption>
<title>Dimensional requirements for different vehicle types within the Japanese
regulation</title>
</caption>
<table width="652">
<col width="25%"/>
<col width="25%"/>
<col width="25%"/>
<col width="25%"/>
<thead>
```

#### IEC

In IEC, the width of each column is captured as a percentage. No absolute number of pixels is indicated for table width.

For example:

```
<table-wrap id="tab-1">
<label>Table 1</label>
<caption>
<title>Spectrum analyser parameters</title></caption>
<table>
<colgroup>
<col align="center" valign="middle" width="12%"/>
<col align="center" valign="middle" width="22%"/>
<col align="center" valign="middle" width="14%"/>
<col align="center" valign="middle" width="10%"/>
<col align="center" valign="middle" width="10%"/>
<col align="center" valign="middle" width="18%"/>
<col align="center" valign="middle" width="14%"/></colgroup>
<thead>
```

## 6.2 Table headers

Table headers and footers are coded in `<thead>` and `<table-wrap-foot>` respectively.

## ISO

Table header rows include **<bold>** formatting.

```
<thead>
<tr>
<th><bold>Bacteria species</bold></th>
<th><bold>WDCM code</bold></th>
</tr>
</thead>
```

## IEC

Table headers are not tagged as **<bold>** – they are bolded automatically during rendering at IEC. Non-bold text inside a table header is put inside **<roman>** tags to ensure plain formatting.

For example:

**Table 1 – Working example for gamma distortion from viewing direction**

Reporting – Sample data						
Grey-scale luminance and gamma values at various angles						
Level designation	Grey level,	Luminance values from different angles $L(\theta, \Phi)$				
	$V_j$	$L(0,0)$	$L(-20, 180)$	$L(20, 0)$	$L(20, 90)$	$L(-20, 270)$
White (9)	255	555,7	181,2	180,3	160,8	164,7

is coded as:

```
<th>Grey level,
<p id="p-101"><italic>V</italic>_{<roman>j</roman>}</p></th>
```

### 6.3 Layout of content inside cells

The text content of cells should be coded according to the instructions for coding text, except that spacing and line breaks should be handled differently.

- Alignment of content within columns should be done using row subdivisions, rather than line breaks inside one row.
- The presence of merged or split cells should be reflected in the coding by using column or row span tags (see *Merged cells*).
- Alignment of text in a cell should be reflected in the alignment coding, rather than by using spacing.

### 6.4 Formal vs informal tables

A formal table consists of at least a label and a table, normally also a title, captured within **<table-wrap>**.

An informal table does not have a caption (label and title) and is captured as a **<table>** in **<array>**.



## 6.5 Informal tables

Structured information presented in tabular format, but which does not have a label, is captured using `<table>` inside `<array>`.

## 6.6 Formal tables

### 6.6.1 General

In ISO and IEC documents, all table elements are coded in `<table>` within `<table-wrap>`, using XHTML.

#### Attribute of `<table-wrap>`

`@id` – usually contains the number of the table (e.g. "tab-1" or "tab\_1").

### 6.6.2 Designation

A table designation is normally placed above formal tables, e.g. "Table 1 – Alphabetical list of definitions".

The XHTML table model requires the two elements that make up the designation, label ("Table 1") and title ("Alphabetical list of definitions"), to be tagged inside two different hierarchical elements:

- Directly below `<table-wrap>`, use `<label>` to code the label, without the trailing dash and without spaces.
- Then, inside a `<caption>` element, use `<title>` to code the title.

For example:

```
<table-wrap id="tab-1">
<label>Table 1</label>
<caption>
<title>Alphabetical list of definitions</title></caption>
<table>
<colgroup>
```

### 6.6.3 Table notes and footnotes

Table notes and footnotes are coded inside `<table-wrap>` within `<table-wrap-foot>`.

References to table footnotes (footnotes that are associated with the table and contained within `<table-wrap>`) generally have an ID constructed from the table number and footnote number.

- `@ref-type`
- `@id` of the footnote

#### ISO

Table footnotes are coded using `<fn>` with `@id` prefixed with "table-fn" instead of "fn".

`@ref-type` has a value of "table-fn".

The `@id` should be in the following format

Formal tables: **table-fn\_[table footnote sequence within the document]**

Informal tables: **table-fn\_[id of the informal table].[fn sequence within the table]**

For example, for footnote 1 of table 2: table-fn\_2.1.

Frequency bandwidth	One-third-octave mid-band frequency Hz	Standard deviation of reproducibility, $\sigma_{R0}$ dB
One-third-octave	100 to 160	3,0
	200 to 315	2,0
	400 to 5 000	1,5
	6 300 to 10 000	2,5
A-weighted per Annex E		1,5 <sup>a</sup>

<sup>a</sup> Applicable to noise sources which emit sound with a relatively "flat" spectrum in the frequency range from 100 Hz to 10 000 Hz.

is coded as:

```

<table-wrap id="tab_2">
 <label>Table 2</label>
 <caption>
 <title>Typical upper bound values of the standard deviation of reproducibility of
 the method, σ_{R0}, for sound power levels and
 sound energy levels determined in accordance with this International Standard</title>
 </caption>
 <table border="1" frame="box" rules="all">
 <colgroup>
 <col align="center" valign="middle" width="112.35"/>
 <col align="center" valign="middle" width="130.40"/>
 <col align="center" valign="middle" width="130.40"/>
 </colgroup>
 <thead>
 <tr>
 <th>Frequency bandwidth</th>
 <th>One-third-octave mid-band frequency
Hz</th>
 <th>Standard deviation of reproducibility, σ_{R0}
dB</th>
 </tr>
 </thead>
 <tbody>
 <tr>
 <td rowspan="4">One-third-octave</td>
 <td>100 to 160</td>
 <td>3,0</td>

 </tr>
 <tr>
 <td align="left" colspan="2">A-weighted per Annex E</td>
 <td>1,5^a<xref ref-type="table-fn" rid="table-
 fn_2.1">^a</xref></td>
 </tr>
 </tbody>
 </table>
 <table-wrap-foot>
 <fn id="table-fn_2.1"><label>^a</label><p>Applicable to noise
 sources which emit sound with a relatively "flat" spectrum in the frequency range
 from 100 Hz to 10 000 Hz.</p></fn>
 </table-wrap-foot>
</table-wrap>

```

## Legacy tagging

In legacy content, table footnotes were captured in `<tfoot>`. Going forward, `<table-wrap-foot>` is the preferred and used element.

## IEC

`@ref-type` has a value of "fn".

`@id="tfn-x-y"` where "x" is the table number as coded in `<label>` and "y" is the sequential number of the footnote inside the table.

For example:

Ref. Clause	Requirement	Method (one or more of the specified methods apply)		
		Analysis	Testing	Visual inspection
4.7.3.4	Additional requirements for the EMS function	X <sup>a</sup>	X <sup>a</sup>	X <sup>a</sup>
4.8	Reset		X	
4.15	Configurability protection		X	

<sup>a</sup> All marked methods apply for this verification

is coded as:

```
<table-wrap id="tab-4">
...
<table>
...
<thead>
<tr>
<th>Ref. Clause</th>
<th>Requirement</th>
<th>Method (one or more of the specified methods apply)</th></tr>
<tr>
<th>Analysis</th>
<th>Testing</th>
<th>Visual inspection</th></tr></thead>
<table-wrap-foot>
<tr>
<td colspan="5" style="padding: 0 3.5px 0 3.5px;">
<fn id="tfn-4-1">
<label>a</label>
<p id="p-204">All marked methods apply for this verification</p></fn></td></tr></table-wrap-foot>
<tbody>
<tr>
<td style="padding: 0 3.5px 0 3.5px;"><xref ref-type="sec" rid="sec-4.7.3.4">4.7.3.4</xref></td>
<td style="padding: 0 3.5px 0 3.5px;">Additional requirements for the <xref ref-type="other" rid="abb-ems">EMS</xref> function</td>
<td style="padding: 0 3.5px 0 3.5px;">X<xref ref-type="fn" rid="tfn-4-1">a</xref></td>
<td style="padding: 0 3.5px 0 3.5px;">X<xref ref-type="fn" rid="tfn-4-1">a</xref></td>
<td style="padding: 0 3.5px 0 3.5px;">X<xref ref-type="fn" rid="tfn-4-1">a</xref></td>
<td style="padding: 0 3.5px 0 3.5px;" /></tr>
<tr>
...

```

## 6.6.4 Unit statements in table headers

When units used in a column are indicated in a table header, these are coded in a separate row, inside **<th>** elements.

For example:

Conditions	Cooling medium	Minimum	Maximum
		°C	°C
Temporary extreme temperatures of the cooling medium	Air	0	40
	Water	+ 5	30
	Oil	- 5	30
Daily average	Air		30
Yearly average	Air		25

is coded as:

```

<table-wrap id="tab-6">
<label>Table#160;6</label>
<caption>
<title>Limit of temperature of the cooling medium for indoor equipment</title></caption>
<table>
<colgroup>
<col align="left" valign="top" width="44%"/>
<col align="center" valign="middle" width="20%"/>
<col align="center" valign="middle" width="18%"/>
<col align="center" valign="middle" width="18%"/></colgroup>
<thead>
<tr>
<th>Conditions</th>
<th>Cooling medium</th>
<th>Minimum</th>
<th>Maximum</th></tr>
<tr>
<th><roman>#176;C</roman></th>
<th><roman>#176;C</roman></th>
</tr></thead>
<tbody>
<tr>
<td rowspan="3" style="padding: 2px 3.5px 2px 3.5px;">Temporary extreme temperatures of the cooling
medium</td>
<td style="padding: 2px 3.5px 2px 3.5px;">Air</td>
<td style="padding: 2px 3.5px 2px 3.5px;">0</td>
<td style="padding: 2px 3.5px 2px 3.5px;">40</td></tr>
<tr>
<td style="padding: 2px 3.5px 2px 3.5px;">Water</td>
<td style="padding: 2px 3.5px 2px 3.5px;">+ 5</td>
<td style="padding: 2px 3.5px 2px 3.5px;">30</td></tr>
<tr>
<td style="padding: 2px 3.5px 2px 3.5px;">Oil</td>
<td style="padding: 2px 3.5px 2px 3.5px;">− 5</td>
<td style="padding: 2px 3.5px 2px 3.5px;">30</td></tr>
<tr>
<td style="padding: 2px 3.5px 2px 3.5px;">Daily average</td>
<td style="padding: 2px 3.5px 2px 3.5px;">Air</td>
<td style="padding: 2px 3.5px 2px 3.5px;">/>
<td style="padding: 2px 3.5px 2px 3.5px;">30</td></tr>
<tr>
<td style="padding: 2px 3.5px 2px 3.5px;">Yearly average</td>
<td style="padding: 2px 3.5px 2px 3.5px;">Air</td>
<td style="padding: 2px 3.5px 2px 3.5px;">/>
<td style="padding: 2px 3.5px 2px 3.5px;">25</td></tr></tbody></table></table-wrap>

```



### 6.6.5 General unit statements in tables

When a table contains text describing the units used in the table it is captured as `<p>` with `@content-type="dimension"` in `<table-wrap-foot>`.

For example:

Designation	Quality	C max.	Mn max.	P max.	S max.	Sj <sup>a</sup>
HRA	Commercial	0,15	0,70	0,045	0,035	—

is coded as:

```

</table>
<table-wrap-foot>
 <p content-type="Dimension" specific-use="100">Mass fractions in per cent</p>
</table-wrap-foot>
</table-wrap>

```

#### ISO:

In this context, `@specific-use` at ISO is a layout instruction.

## 7 Formulae and equations

### 7.1 Elements and attributes

A full formula/equation that is separate from the surrounding text is coded using `<disp-formula>`. If a full formula/equation is embedded in the flow of the text that surrounds it, it should be captured in `<inline-formula>`.

Symbols for variable quantities without operators that appear within the flow of text should be coded as normal text, formatted as they appear in the text, including font information (e.g. TNR). Symbols should be captured in UTF-8 codepoint.

Numbered formulae usually are separated from the text and labelled with a number in parentheses, e.g. (1). This number is usually sequential and numbered independently throughout the document, irrespective the numbering of any containing clauses. Numbered formulae contained in annexes are prefixed by the annex letter.

For numbered formulae, the formula number should also be captured as a `<label>` within the `<disp-formula>`, e.g.

```
<disp-formula id="formula_1">
 <label>(1)</label>
 <mml:math id="mml_m1">
 ...
 </mml:math>
</disp-formula>
```

## 7.2 Numbered formulae

For numbered formulae, the formula ID should match the label of the formula.

### ISO

For example, *formula\_1* for Formula 1.

```
<disp-formula id="formula_1">
<label>(1)</label>
```

### IEC

For example, *for-1* for Formula 1.

```
<disp-formula id="for-1">
<label>(1)</label>
```

## 7.3 Unnumbered formulae

### ISO

For unnumbered formulae, there are no formula IDs on **<inline-formula>**. IDs may be found on the captured mathML element within **<inline-formula>**.

### IEC

Unnumbered formulae can appear inline, but also as block formulae.

For inline formulae, there are no IDs on **<inline-formula>** itself, but on the MathML element within **<inline-formula>**.

For unnumbered block formulae, the formula ID uses the structure "for-informal-X-Y", where X is the number of the subclause and Y the sequential number of the unnumbered formula inside the subclause, for example:

```
<disp-formula id="for-informal-5.1.3-1">
```

Generally, **<disp-formula>** is used for unnumbered block formulae.

### Legacy tagging

However, some legacy coding uses **<inline-formula>** with **@display="block"** in the respective **<mml:math>**:

```
<inline-formula id="for-informal-8.3.1-1">
<mml:math display="block" id="mml-m1">
<mml:mrow>
...

```

#### 7.4 Groups of formulae

Formulae that are grouped together on one line are coded as **<disp-formula-group>**. Text between the individual formulae is coded inside **<disp-formula-group>** but outside **<mml:math>**.

The ID follows the pattern "forg-informal-X-Y", where X is the number of the subclause and Y is the sequential number of the formula group inside that subclause.

For example:

$$a = \frac{E_1}{E_2} k \left( \frac{d_2}{d_1} \right)^x, \quad \text{or} \quad a = \frac{H_1}{H_2} k \left( \frac{d_2}{d_1} \right)^x \quad (5)$$

is coded as:



```
<disp-formula-group id="forg-informal-5.3.1-1">
<disp-formula id="for-5">
<label>(5)</label>
<mml:math id="mml-m6">
<mml:mrow>
<mml:mi>a</mml:mi>
<mml:mspace/>
<mml:mo>=</mml:mo>
<mml:mspace/>
<mml:mfrac>
<mml:msub>
<mml:mi>E</mml:mi>
<mml:mn>1</mml:mn></mml:msub>
<mml:msub>
<mml:mi>E</mml:mi>
<mml:mn>2</mml:mn></mml:msub></mml:mfrac></mml:mrow>
<mml:mi>k</mml:mi>
<mml:msup>
<mml:mrow>
<mml:mo>(</mml:mo>
<mml:mfrac>
<mml:msub>
<mml:mi>d</mml:mi>
<mml:mn>2</mml:mn></mml:msub>
<mml:msub>
<mml:mi>d</mml:mi>
<mml:mn>1</mml:mn></mml:msub></mml:mfrac>
<mml:mo>)</mml:mo></mml:mrow>
<mml:mi>x</mml:mi></mml:msup></mml:math>, or</disp-formula>
<disp-formula id="for-5a">
<mml:math id="mml-m7">
<mml:mrow>
<mml:mi>a</mml:mi>
<mml:mspace/>
<mml:mo>=</mml:mo>
<mml:mspace/>
<mml:mfrac>
<mml:msub>
<mml:mi>H</mml:mi>
<mml:mn>1</mml:mn></mml:msub>
<mml:msub>
<mml:mi>H</mml:mi>
<mml:mn>2</mml:mn></mml:msub></mml:mfrac></mml:mrow>
<mml:mi>k</mml:mi>
<mml:msup>
<mml:mrow>
<mml:mo>(</mml:mo>
<mml:mfrac>
<mml:msub>
<mml:mi>d</mml:mi>
<mml:mn>2</mml:mn></mml:msub>
<mml:msub>
<mml:mi>d</mml:mi>
<mml:mn>1</mml:mn></mml:msub></mml:mfrac>
<mml:mo>)</mml:mo></mml:mrow>
<mml:mi>x</mml:mi></mml:msup></mml:math></disp-formula></disp-formula-group>
```

## ISO

ISO does not use formula groups.

## 7.5 Formula keys

Keys to a formula (following the pattern "where X = Y") are coded as **<def-list>** with *@list-content="formula"*, with the word "where" as the **<label>**. The elements of that list are coded as pairs inside **<def-item>**. Each **<def-item>** contains one **<term>** and one **<def>**.

For example:

$$L = \frac{\mu l}{2\pi} \left[ \ln\left(\frac{4l}{d}\right) - 1 \right] \text{ H}$$

where

$\mu$	= $4\pi \times 10^{-7}$ H/m;
$l$	is the length of the wire in m;
$d$	is the diameter of the wire in m.

is coded as:

```
<def-list list-content="formula">
<label>where</label>
<def-item>
<term>μ</term>
<def>
<p id="p-183">= $4\pi \times 10^{-7}$ H/m;</p></def></def-item>
<def-item>
<term>l</term>
<def>
<p id="p-184">is the length of the wire in m;</p></def></def-item>
```

### IEC

**Legacy tagging** at IEC sometimes uses **<def-head>** instead of **<label>** to code the word "where".

**<def-list>** only allows the coding of pairs of **<term>** and **<def>**. If there is more than one definition for each **<term>** (e.g. a definition text and a symbol), a regular table will be used to code the key.

### ISO

#### Under investigation for future implementation:

ISO aims to align with the Guidelines and use the above.

Until this is integrated into the ISO/CS production chain, formula keys will be coded in **<array>**.

Example:

```

<p>where</p>
<array id="tab_c">
<table width="652">
<col width="4.08%"/>
<col width="5.81%"/>
<col width="90.11%"/>
<tbody>
<tr>
<td align="left" scope="row" valign="top"> </td>
<td align="left" valign="top"><italic>P</italic></td>
<td align="left" valign="top">is the bacterial concentration (cfu/ml);</td>
</tr>
<tr>
<td align="left" scope="row" valign="top"> </td>
<td align="left" valign="top"><italic>Z</italic></td>
<td align="left" valign="top">is the average number of colonies in the three Petri dishes
(cfu);</td>
</tr>
<tr>
<td align="left" scope="row" valign="top"> </td>
<td align="left" valign="top"><italic>D</italic>_F</td>
<td align="left" valign="top">is the dilution factor.</td>
</tr>
</tbody></table></array>

```

## 7.6 MathML

The mathematical expression within the **<disp-formula>** or **<inline-formula>** is coded using **<mml:math>**. Its visual representation should be preserved as closely as possible, including spacing.

Every **<mml:math>**, irrespective of whether it is contained in a **<disp-formula>** or an **<inline-formula>** element, contains an *@id* number which may be different from the label of the **<disp-formula>**.

If one **<disp-formula>** contains more than one mathematical expression laid out on separate lines, these are contained in one **<mml:math>**.

The *@id* is prefixed "mml\_m[number]", with [number] representing the sequential position of the **<mml:math>** element in the document, for example:

```

<disp-formula id="formula_1">
 <label>(1)</label>
 <mml:math id="mml_m5">
 ...
 </mml:math>
</disp-formula>

```

The ID corresponds to the name of a graphical representation of the formula (*.png*) that is delivered inside the asset folder and can be used as an alternative in case of problems with the rendering of MathML.

No detailed instructions are provided here for the coding of MathML; we assume that this will be handled by a specialized WYSIWYG tool that will generate the codes automatically.

## 8 Figures

### 8.1 Elements and attributes

#### Editorial note

A figure is made up of at least an image and a designation "Figure # – Title of Figure",  
e.g: **Figure 1 – Rigid steel plate.**

The figure is coded in **<fig>**.

Within **<fig>**,

- the figure number is coded in **<label>**
- the figure designation is coded in **<title>** within **<caption>**, e.g.:

```
<fig id="fig-1">
<label>Figure 1</label>
<caption>
<title>Overview of the dictionary schema</title></caption>
<graphic xlink:href="asset/fig-1"/></fig>
```

- information about the image file is coded in **<graphic>** (see 5.10)
- figure notes are coded in **<non-normative-note>**
- paragraphs between the graphic and the figure designation are coded in **<p>**
- a figure key is coded as described in

#### Attributes of **<fig>**

##### ISO

*@id* – fig\_X, where X is the figure number contained in the label.

*@fig-type* – usually this has a value of "figure".

##### IEC

*@id* – fig-X, where X is the figure number contained in the label.

### 8.2 Sub-figures and multiple graphics within a figure

#### ISO

The caption of a sub-figure (e.g. "a) - title of sub-figure") is coded in **<title>** within a **<caption>** within the **<graphic>**.

The rest of the sub-figure caption should be captured as a label within the **<graphic>** (excluding any trailing dash), for example:

```
<graphic xlink:href="fig_1.1" id="fig_1.1">
 <label>a</label>
 <caption><title>title of sub-figure</title></caption>
</graphic>
```

## IEC

If the figure contains multiple graphics, then each graphic is captured as a separate **<graphic>** within **<fig>**.

If the figure consists of multiple sub-figures (each with their own caption), then each subfigure is captured as a separate **<fig>** inside **<figure-group>**.

Each sub-figure has an *@id* based on its label.

For example:

```
<fig-group id="fig-3">
 <label>Figure 3</label>
 <caption>
 <title>Example for a typical cable arrangement for measurements of radiated disturbances in
 3 m separation distance, Table-top EUT</title></caption>
 <fig id="fig-3a">
 <label>Figure 3a</label>
 <caption>
 <title>Top view</title></caption>
 <graphic xlink:href="asset/fig-3a"/></fig>
 <fig id="fig-3b">
 <label>Figure 3b</label>
 <caption>
 <title>Side view</title></caption>
 <graphic xlink:href="asset/fig-3b"/></fig></fig-group>
```

## 8.3 Figure key

### Editorial note

A figure key is preceded by the title "Key".

### ISO

In ISO, the figure key is coded in **<table>** within **<table-wrap>** inside **<fig>** with a content-type attribute of "fig-index".

### IEC

In IEC, the figure key is coded within **<def-list>** inside **<fig>**, with *@list-content="figure"*

## 8.4 Unit statements in figures

When a figure contains a unit statement such as "Dimensions in millimetres", this is coded as as **<p>** with *@content-type="dimension"*.

For example the unit statement in this figure:



Dimensions in millimetres

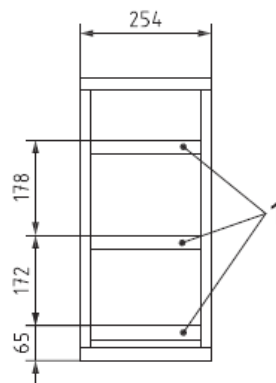

Key  
1 metal angle frame

Viscometer speed	Shear rate
29,40	25
58,80	50
88,20	75
117,6	100

Figure 9 — Support rack for plastic sheets

is coded as:

`<p content-type="Dimension" specific-use="100">Dimensions in millimeters</p>`

**ISO:**

In this context, *@specific-use* at ISO is a layout instruction.

## 8.5 Sample coding of a figure

Sample figure:

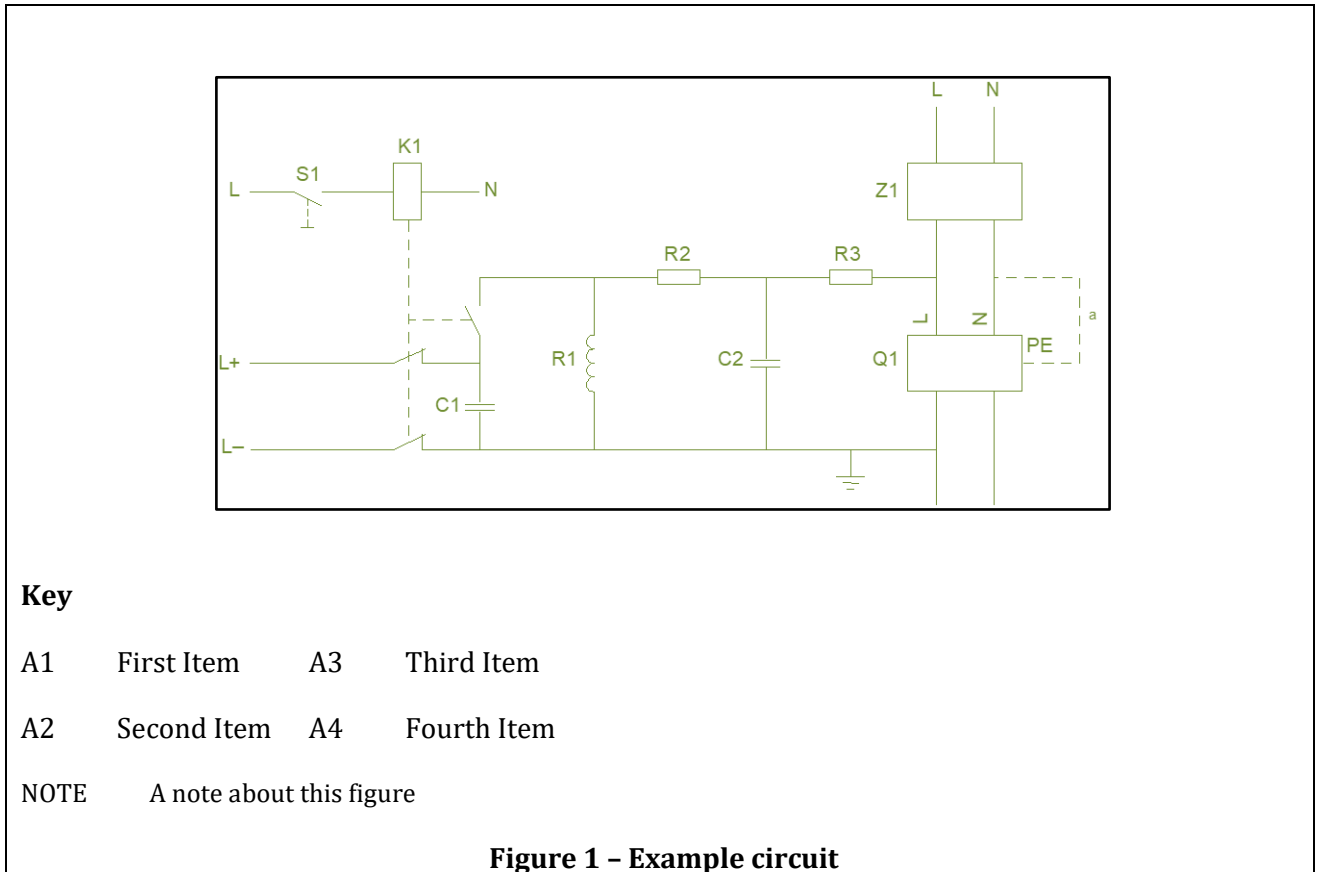

Sample coding:

## ISO

```

<fig id="fig_1">
 <label>Figure 1</label>
 <caption><title>Example circuit</title></caption>
 <graphic xlink:href="fig_1"/>
 <table-wrap content-type="fig-index">
 <caption><title>Key</title></caption>
 <table>
 <colgroup>
 <col width=15/>
 <col width=150/>
 <col width=15/>
 <col width=150/>
 </colgroup>
 <tbody>
 <tr>
 <td>A1</td>
 <td>First Item</td>
 <td>A3</td>
 <td>Third Item</td>
 </tr>
 <tr>
 <td>A2</td>
 <td>Second Item</td>
 <td>A4</td>
 <td>Fourth Item</td>
 </tr>
 </tbody>
 </table>
 </table-wrap>
 <non-normative-note>
 <label>NOTE</label>
 <p>A note about this figure</p>
 </non-normative-note>
</fig>

```

IEC

For example:

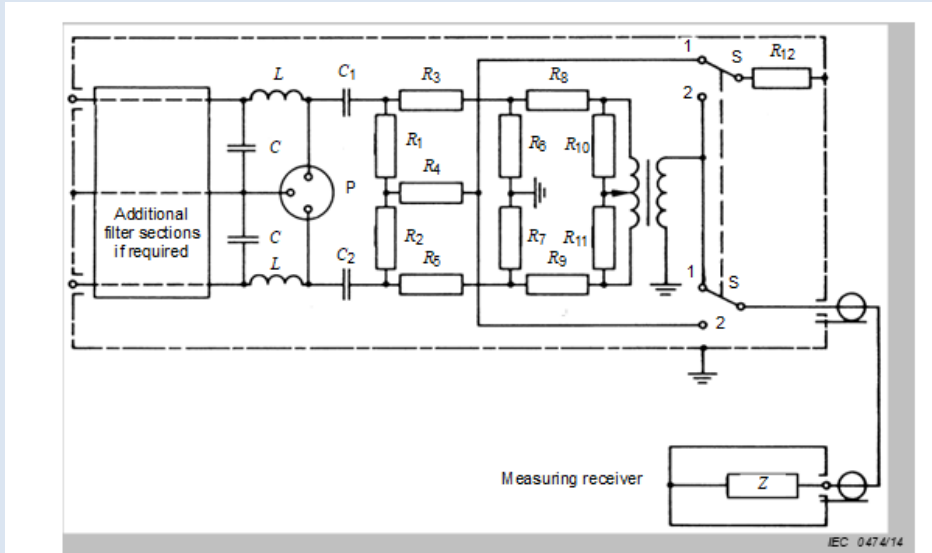

**Key**

- P is the connection for apparatus under test
- 1 for the symmetric component
- 2 for the asymmetric component
- S double pole double throw switch
- Z measuring receiver input impedance

**Figure A.2 – Example of a  $\Delta$ -AMN for a measuring receiver with unbalanced input**

is coded as:

```

<fig id="fig-A.2">
<label>Figure A.2</label>
<caption>
<title>Example of a 150 Ω <xref ref-type="other" rid="abb-#x03b4;-an">Δ-
AN</xref> for low current drain across the AN for the measurement of asymmetric and
symmetric disturbance voltages</title></caption>
<graphic xlink:href="asset/fig-A.2"/>
<def-list list-content="figure">
<label>Key</label>
<def-item>
<term id="figk-A.2-1">P</term>
<def>
<p id="p-256">EUT port of the AN</p></def></def-item>
<def-item>
<term id="figk-A.2-2">1</term>
<def>
<p id="p-257">switch position for measurement of the symmetric voltage
component</p></def></def-item>
<def-item>
<term id="figk-A.2-3">2</term>
<def>
<p id="p-258">switch position for measurement of the asymmetric voltage
component</p></def></def-item>
<def-item>
<term id="figk-A.2-4">S</term>
<def>
<p id="p-259">double pole double throw switch</p></def></def-item>
<def-item>
<term id="figk-A.2-5"><italic>Z</italic></term>
<def>
<p id="p-260">measuring receiver input impedance</p></def></def-item></def-list></fig>

```

## 9 Terms and definitions

### 9.1 Subclauses inside a "Terms and Definitions" clause

The terms and definitions clause can be subdivided: either to organize and group similar concepts, or to separate a terms and definitions subclause from another subclause, such as abbreviated terms.

#### 3.1.3 sound pressure

*p*  
fluctuating pressure superimposed on the static pressure

Note 1 to entry: Sound pressure is expressed in pascal.

Note 2 to entry: Sound pressure is usually expressed through the use of a decibel scale, as sound pressure level (see 3.1.4).

is coded as:

```

<term-sec id="con-3.1.3">
<label>3.1.3</label>
<tbx:termEntry id="te-3.1.3">
<tbx:langSet xml:lang="en">
<tbx:definition>fluctuating pressure superimposed on the static pressure</tbx:definition>

```



```
<tbx:note id="nte-3.1.3-1">Sound pressure is expressed in pascal.</tbx:note>
<tbx:note id="nte-3.1.3-2">Sound pressure is usually expressed through the use of a decibel scale,
as sound pressure level (see <xref ref-type="other" rid="con-3.1.4">3.1.4</xref>).</tbx:note>
<tbx:tig>
<tbx:term id="ter-sound_pressure">sound pressure</tbx:term>
<tbx:partOfSpeech value="noun"/>
<tbx:normativeAuthorization value="preferredTerm"/>
<tbx:termType value="fullForm"/></tbx:tig>
<tbx:tig>
<tbx:term id="ter-p"><italic>p</italic></tbx:term>
<tbx:partOfSpeech value="noun"/>
<tbx:normativeAuthorization value="admittedTerm"/>
<tbx:termType value="symbol"/></tbx:tig>
</tbx:langSet></tbx:termEntry></term-sec>
```

## 9.2 Usage of TBX vs. <term-display>

### 9.2.1 General

There are two different options for tagging terms and definitions. Both structures occur optionally inside a the <term-sec> container element:

- one is TBX
- the other is a simpler, less powerful alternative, <term-display>.

<b>ISO</b> ISO uses TBX exclusively.
<b>IEC</b> IEC uses TBX wherever possible. In redline documents and certain series where the elements are arranged in a special way and layout is important to the entry, IEC also uses <term-display>, as described in 9.4.

The <term-sec> container element also includes <label>, which contains the number of the terminological entry.

### 9.2.2 TBX (based exclusively on semantic information)

TBX is a concept-oriented exchange format for data from terminological databases. The TBX element <tbx:termEntry> models a term using the TBX-namespace vocabulary and ontology for terms. It can record information about any number of synonymous terms and multiple languages. The TBX vocabulary in NISO STS is derived and extended from ISO 30042. For usage information and contents, see the documentation at: <https://www.iso.org/schema/nisosts/v0.2/doc/tbx/index.html>

### 9.2.3 <term-display> (more appearance oriented)

The NISO STS element <term-display> uses natural language to describe terms, and may incorporate semantic term elements such as definition (<def>) and part of speech (<part-of-speech>). Semantic tagging is encouraged, but not enforced. It is a more appearance-oriented encoding of terminological data that may be used when:

- a standards organization chooses not to employ TBX
- it is difficult to generate the desired formatted display from a TBX entry



- converting back-catalogue documents, in cases where it is difficult to create a useful TBX term entry from an appearance-oriented input document

Generally, ISO and IEC will use TBX. In some cases of legacy conversion, however, IEC uses **<term-display>** to ensure all elements are correctly displayed. For usage, see 9.4 below.

## 9.3 Terminological entries in TBX

### 9.3.1 Terms and definitions

A terminological entry (**<tbx:termEntry>**) contains these core components (inside **<tbx:langSet>**):

- Terms and their description (each term coded inside its own **<tbx:tig>**) – see 9.3.3
- Definition (**<tbx:definition>**) – see 9.3.2

For further information about these and other elements of TBX, see <https://www.iso.org/schema/nisosts/v0.2/doc/tbx/index.html>.

The ID of the terminological entry is derived from the entry number contained in **<label>** and is used for both **<term-sec>** and **<tbx:termEntry>**. IEC has an *@id* on **<tbx:term>** as well.

#### ISO

**<term-sec>**: *@id* has prefix “sec\_”

**<tbx:term-entry>**: *@id* has prefix “term\_”

```
<term-sec id="sec_3.1">
 <label>3.1</label>
 <tbx:termEntry id="term_3.1">
 <tbx:langSet xml:lang="en">
 <tbx:definition>The point in an encoding...boundary.</tbx:definition>
 <tbx:tig>
 <tbx:term>alignment point</tbx:term>
 <tbx:partOfSpeech value="noun"/>
 </tbx:tig>
 </tbx:langSet>
 </tbx:termEntry>
</term-sec>
```

#### IEC

**<term-sec>**: *@id* has prefix “con-”

**<tbx:term-entry>**: *@id* has prefix “te-”

**<tbx:term>**: *@id* corresponds to the term itself

```
<term-sec id="con-3.1.3">
<label>3.1.3</label>
<tbx:termEntry id="te-3.1.3">
<tbx:langSet xml:lang="en">
<tbx:definition>fluctuating pressure superimposed on the static pressure</tbx:definition>
<tbx:note id="nte-3.1.3-1">Sound pressure is expressed in pascal.</tbx:note>
<tbx:note id="nte-3.1.3-2">Sound pressure is usually expressed through the use of a decibel
scale, as sound pressure level (see <xref ref-type="other" rid="con-
3.1.4">3.1.4</xref>).</tbx:note>
<tbx:tig>
<tbx:term id="ter-sound_pressurep">sound pressure</tbx:term>
<tbx:partOfSpeech value="noun"/>
<tbx:normativeAuthorization value="preferredTerm"/>
<tbx:termType value="fullForm"/></tbx:tig>
```

```

<tbx:tig>
<tbx:term id="ter-p"><italic>p</italic></tbx:term>
<tbx:partOfSpeech value="noun"/>
<tbx:normativeAuthorization value="admittedTerm"/>
<tbx:termType value="symbol"/></tbx:tig>
</tbx:langSet></tbx:termEntry></term-sec>

```

### 9.3.2 Definitions

A definition is coded in **<tbx:definition>**, inside **<tbx:langSet>**.

A **<break/>** can be used to insert a line break in a definition if necessary.

### 9.3.3 Terms and additional information on them

Each term and its descriptive elements are contained in one individual **<tbx:tig>** (term information group). Terms are coded inside **<tbx:term>**, which is mandatory.

The elements used at ISO and IEC to describe terms are currently:

- **<tbx:partOfSpeech>** (mandatory)
- **<tbx:normativeAuthorization>**
- **<tbx:termType>**
- **<tbx:grammaticalNumber>**

**<tbx:geographicalUsage>** and **<tbx:grammaticalGender>** will probably be used in the future.

#### "Part of speech" of a term

**<tbx:partOfSpeech>** is mandatory.

Possible values:

- noun
- verb
- adj
- adv

In NISO STS v. 1.0, there is no value "undefined". Therefore, all legacy conversion uses "noun" as the default value. While this may be correct in most cases, it is not a reliable value. We therefore recommend not basing any programming on this value for now.

For example:

```

3.1
electro-pneumatic continuous pressure control valve
control valve which continuously modulates the pneumatic power of a system in response to a continuous
electrical input signal and which links the electrical input quantity to a pressure value

```

is coded as:



```

<term-sec id="sec_3.1">
 <label>3.1</label>
 <tbx:termEntry id="term_3.1">
 <tbx:langSet xml_lang="en">
 <tbx:definition>control valve which continuously modulates the pneumatic power
of a system in response of a continuous electrical input signal and which links the
electrical input quantity to a pressure value</tbx:definition>
 <tbx:tig>
 <tbx:term>electro-pneumatic continuous pressure control valve</tbx:term>
 <tbx:partOfSpeech value="noun"/>
 </tbx:tig>
 </tbx:langSet>
 </tbx:termEntry>
</term-sec>

```

### Form of the term (<tbx:termType>)

<tbx:termType> is optional but is generally used at ISO and IEC. If it is used, it can have these values in the ISO/IEC context:

- acronym
- abbreviation
- fullForm (default value, can be omitted)
- symbol
- formula
- equation

For example:

```

3.13
data monitoring committee
DMC
independent committee that may be established by the sponsor to assess, at intervals, the progress of the
clinical investigation, the safety data or the critical performance endpoints and to recommend the sponsor
whether to continue, suspend, modify, or stop the clinical investigation

```

is coded as:

```

<term-sec id="sec_3.13">
 <label>3.13</label>
 <tbx:termEntry id="term_3.13">
 <tbx:langSet xml_lang="en">
 <tbx:definition>independent committee that may be...
investigation</tbx:definition>
 <tbx:tig>
 <tbx:term>data monitoring committee</tbx:term>
 <tbx:partOfSpeech value="noun"/>
 </tbx:tig>
 <tbx:tig>
 <tbx:term>DMC</tbx:term>
 <tbx:partOfSpeech value="noun"/>
 <tbx:termType value="abbreviation"/>
 </tbx:tig>
 </tbx:langSet>
 </tbx:termEntry>
</term-sec>

```



## Term status (<tbx:normativeAuthorization>)

<tbx:normativeAuthorization> is an optional element indicating the status of a term. It is generally used at ISO/IEC and can have these values:

- preferred (recommended)
- admitted (allowed)
- deprecated (for deprecated or obsolete terms, superseded terms, archaic terms, scientific-technical slang, terms indicated as “deprecated in this sense” [IEV] and other terms which are detrimental to domain communication)

For example:

```
<term-sec id="con-3.9">
<label>3.9</label>
<tbx:termEntry>
<tbx:langSet xml:lang="en">
<tbx:definition>radiant power incident on an element of a surface divided by the area of that
element</tbx:definition>
<tbx:source>
<std std-id="urn:iec:std:iec:60050-731:1991-12::#con-731-1-25">
<std-ref>IEC 60050‑731:1991, 731‑1‑25</std-ref></std></tbx:source>
<tbx:tig>
<tbx:term id="ter-irradiance">irradiance</tbx:term>
<tbx:normativeAuthorization value="preferredTerm"/>
<tbx:termType value="fullForm"/></tbx:tig>
<tbx:tig>
<tbx:term id="ter-intensity">intensity</tbx:term>
<tbx:normativeAuthorization value="deprecatedTerm"/>
<tbx:termType value="fullForm"/></tbx:tig></tbx:langSet></tbx:termEntry></term-sec>
```

and:

```
<term-sec id="con-3.1">
<label>3.1</label>
<tbx:termEntry>
<tbx:langSet xml:lang="en">
<tbx:definition>fluctuating pressure superimposed on the static (barometric) pressure by the
presence of sound</tbx:definition>
<tbx:note id="nte-3.1-1">It is expressed in pascal, Pa.</tbx:note>
<tbx:tig>
<tbx:term id="ter-sound pressure">sound pressure</tbx:term>
<tbx:normativeAuthorization value="preferredTerm"/>
<tbx:termType value="fullForm"/></tbx:tig>
<tbx:tig>
<tbx:term id="ter-p"><i>p</i></tbx:term>
<tbx:normativeAuthorization value="admittedTerm"/>
<tbx:termType value="symbol"/></tbx:tig></tbx:langSet></tbx:termEntry></term-sec>
```

### 9.3.4 Examples in terminology

When coding with TBX, the "Example" keyword is removed from the content (use <tbx:example>).

For example:

```
3.1
boundaries
physical or site limits and/or organizational limits as defined by the organization

EXAMPLE A process; a group of processes; a site; an entire organization; multiple sites under the control of an
organization.
```

is coded as:

```
<term-sec id="sec_3.1">
 <label>3.1</label>
 <tbx:termEntry id="term_3.1">
 <tbx:langSet xml:lang="en">
 <tbx:definition>physical or site limits... organization</tbx:definition>
 <tbx:example>A process; a group... organization </tbx:example>
 ..
 </term-sec>
```

### 9.3.5 Notes in terminology

Terminological notes ("Note X to entry") are coded as **<tbx:note>**. When coding with TBX, the label "NOTE" or "Note X to entry" (or any other label) is removed from the content.

For example:

```
3.4
audit findings
results of the evaluation of the collected audit evidence (3.3) against audit criteria (3.2)

NOTE 1 Audit findings indicate conformity or nonconformity.

NOTE 2 Audit findings can lead to the identification of opportunities for improvement or recording good practices.
```

is coded as:

```
<term-sec id="sec_3.4">
 <label>3.4</label>
 <tbx:termEntry id="term_3.4">
 <tbx:langSet xml:lang="en">
 <tbx:definition>results of the evaluation of the collected <tbx:entailedTerm
target="term_3.3">audit evidence (3.3)</tbx:entailedTerm> against <tbx:entailedTerm
target="term_3.2">audit criteria (3.2)</tbx:entailedTerm</tbx:definition>
 <tbx:note>Audit findings indicate conformity or nonconformity.</tbx:note>
 <tbx:note>Audit findings can lead to the identification of opportunities for
improvement or recording good practices.</tbx:note>
 </tbx:langSet>
 </tbx:termEntry>
</term-sec>
```

### 9.3.6 Cross-references between terms in the Terms and definitions clause

Cross-references between terminological entries or terms within the Terms and definitions clause can be tagged as **<tbx:entailedTerm>**. This element should only be used in child elements of **<tbx:termEntry>**.

For cross-references to terms external to the document *@xtarget* should be used. *@target* should be used to identify the cross-referenced term entry.

For example:

```
3.3
correction
action to eliminate a detected nonconformity (3.21)

NOTE Adapted from ISO 9000:2005, definition 3.6.6.
```

is coded as:

```

<term-sec id="sec_3.3">
 <label>3.3</label>
 <tbx:termEntry id="term_3.3">
 <tbx:langSet xml:lang="en">
 <tbx:definition>action to eliminate a detected <tbx:entailedTerm
target="term_3.21">nonconformity (3.21)</tbx:entailedTerm></tbx:definition>
 <tbx:note>Adapted from <std><std-ref>ISO 9000:2005</std-ref>, definition
3.6.6</std>.</tbx:note>
 <tbx:tig>
 <tbx:term>correction</tbx:term>
 <tbx:partOfSpeech value="noun"/>
 </tbx:tig>
 </tbx:langSet>
</tbx:termEntry>
</term-sec>

```

### 9.3.7 References to the other sections of the document [within TBX coding]

- Use **<tbx:see>** for references to other clauses, tables, figures etc. in the document.
- If the reference is to only one addressable element (element has an *@id*) and it contains no other explanations, such as "see row 3 of table 3", then the entire reference can be replaced with **<tbx:see target="id of target element">**
- In all other cases provide the text as is (except a distinguishable label such as NOTE: or SEE:) in the **<tbx:see>** element.
- If the reference is still to only one element, provide *@target*.

For example:

```

3.41
subject
individual who participates in a clinical investigation

NOTE See Annex A for more information.

```

is coded as:

```

<term-sec id="sec_3.41">
 <label>3.41</label>
 <tbx:termEntry id="term_3.41">
 <tbx:langSet xml:lang="en">
 <tbx:definition>individual who participates in a clinical investigation
 </tbx:definition>
 <tbx:see target="sec_A"/>
 <tbx:tig>
 <tbx:term>subject</tbx:term>
 <tbx:partOfSpeech value="noun"/>
 </tbx:tig>
 </tbx:langSet>
</tbx:termEntry>
</term-sec>

```

### 9.3.8 Coding the source related to the terminological entry

If there is a stated source for an entry, it is included in **<tbx:source>** within **<tbx:langSet>**. Square brackets or an existing label such as "SOURCE" should be removed from the text.

For example:

**3.7**  
**auditee**  
 organization being audited  
 [ISO 9000:2005, definition 3.9.8]

is coded as:

```
<term-sec id="sec_3.7">
 <label>3.7</label>
 <tbx:termEntry id="term_3.7">
 <tbx:langSet xml:lang="en">
 <tbx:definition>organization being audited </tbx:definition>
 <tbx:source>ISO 9000:2005, definition 3.9.8</tbx:source>
 <tbx:tig>
 <tbx:term>auditee</tbx:term>
 <tbx:partOfSpeech value="noun"/>
 </tbx:tig>
 </tbx:langSet>
 </tbx:termEntry>
</term-sec>
```

Do not code **<std>** for the standards found inside **<tbx:source>**.

### 9.3.9 Subject fields of a terminological entry

In legacy documents, there may be cases where the definition of a term starts with text enclosed in angle brackets (<...>). This should be tagged with **<tbx:subjectField>**, within **<tbx:langSet>**, without capturing the brackets.

**3.6**  
**dispute**  
 (<dispute resolution> disagreement, arising from a **complaint** (3.3), submitted to a **provider** (3.9)

is coded as

```
<term-sec id="sec_3.6">
 <label>3.6</label>
 <tbx:termEntry id="term_3.6">
 <tbx:langSet xml:lang="en">
 <tbx:subjectField>dispute resolution</tbx:subjectField>
 <tbx:definition> disagreement, arising from a <tbx:entailedTerm
target="term_3.3">complaint (3.3)</tbx:entailedTerm>, submitted to a <tbx:entailedTerm
target="term_3.9">provider (3.9)</tbx:entailedTerm></tbx:definition>
 ...
 </tbx:langSet>
 </tbx:termEntry>
</term-sec>
```

### 9.4 Using <term-display> instead of TBX

**<term-display>** is used at IEC for the tagging of terminological entries whose elements are difficult or impossible to represent correctly in TBX, or for entries which are appearance-oriented. Elements are tagged in display sequence.

For example:

### 3 Definitions

This clause of Part 1 is applicable, except as follows:

#### 3.2.9 Replacement:

##### **normal load**

load obtained when the tool is operated continuously, the hose and vibrator bottle being attached to the tool as for normal use. During the operation the vibrator bottle is immersed centrally in a container filled with an amount of water corresponding to at least 50 times the volume of the vibrator bottle.

The dimensions of the container are such that the diameter is about 50 % of the height of the water inside the container.

The height of the container is such that no water can splash out during the test.

*Addition:*

#### 3.101

##### **concrete vibrator**

tool intended for compacting concrete. The active part (vibrator bottle) of the vibrator performs low-amplitude vibrations and is immersed into the mass of concrete to be vibrated. Concrete vibrators may be of one of the following designs:

- the motor and the vibrating mechanism are inside the vibrator bottle to which the part containing the mains switch is connected by means of a long flexible hose containing the interconnecting cable;
- the motor and the vibrating mechanism are inside the vibrator bottle to which a handle, comprising the part containing the mains switch, is fixed by means of a short rigid tube, these parts forming a constructional unit;
- the vibrator mechanism is only inside the vibrator bottle to which a separate portable unit, comprising the motor and the part containing the mains switch, is connected by means of a long flexible hose containing a flexible shaft

is coded as:

```

<sec id="sec-3" sec-type="terms">
<label>3</label>
<title>Terms and definitions</title>
<p id="p-57"><std><std-id link-type="urn" std-id-type="undated">urn:iec:std:iec:60745-1:::sec-3</std-id><std-ref>This clause of Part 1</std-ref></std> is applicable, except as follows:</p>
<term-sec id="con-3.2.9">
<label>3.2.9</label>
<term-display>
<p><i>Replacement:</i></p>
<term id="ter-normal_load">normal load</term>
<def><p>load obtained when the tool is operated continuously, the hose and vibrator bottle being attached to the tool as for normal use. During the operation the vibrator bottle is immersed centrally in a container filled with an amount of water corresponding to at least 50 times the volume of the vibrator bottle.</p>
<p>The dimensions of the container are such that the diameter is about 50 % of the height of the water inside the container.</p>
<p>The height of the container is such that no water can splash out during the test.</p>
</def>
</term-display>
</term-sec>
<term-sec id="con-3.101">
<label>3.101</label>
<p><i>Addition:</i></p>
<term-display>
<term id="ter-concrete_vibrator">concrete vibrator</term>
<def>
<p>tool intended for compacting concrete. The active part (vibrator bottle) of the vibrator performs low-amplitude vibrations and is immersed into the mass of concrete to be vibrated. Concrete vibrators may be of one of the following designs:
<list id="list-3-L1" list-type="alpha-lower">
<list-item id="lis-3-L1-1">
<label>a</label>
<p id="p-58">the motor and the vibrating mechanism are inside the vibrator bottle to which the part containing the mains switch or a power converter and switch handle assembly is connected by means of a long flexible hose containing the interconnecting cable. The long flexible hose may be used as the handle (see <xref ref-type="fig" rid="fig-101">Figure 101</xref>);</p></list-item>
<list-item id="lis-3-L1-2">
<label>b</label>
<p id="p-59">only the vibrator mechanism is inside the vibrator bottle to which a separate portable unit, comprising the motor, the handle and the mains switch, is connected by means of a long flexible hose containing a flexible shaft (see <xref ref-type="fig" rid="fig-102">Figure 102</xref>)</p></list-item></list></p>
</def>
</term-display>
</term-sec></sec>

```

## 10 References

### 10.1 Internal (Cross) References

#### 10.1.1 General

Internal references are tagged as **<xref>**.

##### Attributes of **<xref>**

- **@ref-type** – type of target
- **@rid** – ID of the target

Possible values of **@ref-type**:

- **<xref ref-type="app">**



- `<xref ref-type="bibr">`
- `<xref ref-type="disp-formula">`
- `<xref ref-type="fig">`
- `<xref ref-type="fn">`
- `<xref ref-type="list">`
- `<xref ref-type="sec">`
- `<xref ref-type="table">`
- `<xref ref-type="table-fn">`
- `<xref ref-type="other">` (for `<abb>`, `<term-sec>`, `<tbx:term>`)

For example:

```
<xref ref-type="fn" rid="fn1">1</xref>
```

#### Editorial note

In the Online Collaborative Authoring tool currently under development, cross-references are closed elements. The text of the reference is generated from the ID attribute and the element being referenced. The above example would look like this:

```
<xref ref-type="fn" rid="fn1"/>
```

### 10.1.2 Cross-references to Sections, Tables, Figures and Formulae

References to tables, figures, and formulae in the document should be made using the ID in the respective `<sec>`, `<table-wrap>`, `<fig>`, or `<disp-formula>` to populate `@rid`.

For example:

See Table 2 for an illustration.

is coded as:

```
<p>See <xref ref-type="table" rid="tab_2">Table 2</xref> for an illustration.</p>
```

### 10.1.3 Cross-references to terms

Outside the terms and definitions section, references to terms contained within the document should be made using the id in the terminological entry.

For example:

This term is defined in 3.3.

is coded as:





### ISO

`<p>This term is defined in <xref ref-type="sec" rid="term\_3.3">3.3</xref>.</p>`

### IEC

`<p>This term is defined in <xref ref-type="other" rid="con-3.3">3.3</xref>.</p>`

## 10.1.4 Footnotes

This section deals with body text footnotes, i.e. footnotes inside the regular text. For table footnotes, see 6.6.3.

### Editorial note

Footnotes are normally located at the bottom of an original document page.

References to footnotes are generally represented by superscript characters, usually alpha characters in tables and numerals in the text.

## Footnote references

References to footnotes are tagged as `<xref>` with `@ref-type="fn"`.

### Attributes of `<xref>`

`@ref-type="fn"`

`@rid` – reference to the `@id` of the footnote text

### ISO

ISO provides alphanumeric characters, and sometimes parentheses, within `<label>` and tagged as superscript.

### Example

```
<xref ref-type="fn" rid="fn_1">¹</xref><fn id="fn_1">
<label>¹</label><p> MINITAB is the trade name of a product supplied by Minitab
Inc. JMP is the trade name of a product supplied by SAS Institute Inc. Q-DAS is the trade
name of a product supplied by Q-DAS GmbH. This information is given for the convenience of
users of this document and does not constitute an endorsement by ISO of these
products.</p></fn>
```

### IEC

No `<sup>` is used, the rendering of footnote references is left to the stylesheet, based on the `@ref-type="fn"`.

For example:

Draw the so-called forbidden area symmetrical to the main lobe directions on both sides of the pattern<sup>2</sup> where the amplitude is  $\leq -3$  dB for  $\pm 15^\circ$ .

is coded as:



```
<p id="p-490">Draw the so-called forbidden area symmetrical to the main lobe directions on both sides of the pattern<xref ref-type="fn" rid="foo-1">1</xref>, where amplitude is ≤ –3 dB for ±15°.</p>
```

Footnote references in the bibliography section are coded with <xref>. Their footnote text is added to the document footnotes.

For example:

```
[6] ISO 9000:—1, Quality management systems — Fundamentals and vocabulary
```

is coded as:

```
<ref id="biblref_6"><label>[6]</label><std><std-ref>ISO 9000</std-ref>:<xref ref-type="fn" rid="fn_27">¹</xref>, Quality management systems – Fundamentals and vocabulary</std></ref>
```

### Footnote text

The content of the footnote is tagged as <fn>.

### Attributes of <fn>

@id - should use sequential numbering (order of the footnote inside the document)

<p><b>ISO</b></p> <p>Footnote text is placed at the point of use in the text.</p>
<p><b>IEC</b></p> <p>Going forward, footnote text will be placed at the point of use in the text.</p> <p><b>Legacy tagging:</b></p> <p>Footnote texts are collected inside &lt;fn-group&gt; in &lt;back&gt;. They are the last part of the document,</p> <p>For example:</p> <pre>&lt;fn-group&gt; &lt;fn id="foo-1"&gt; &lt;label&gt;1&lt;/label&gt; &lt;p id="p-396"&gt;Figures between square brackets refer to the &lt;xref ref-type="sec" rid="sec-bibliography"&gt;Bibliography&lt;/xref&gt;.&lt;/p&gt;&lt;/fn&gt; &lt;fn id="foo-2"&gt; &lt;label&gt;2&lt;/label&gt; &lt;p id="p-397"&gt;To be published.&lt;/p&gt;&lt;/fn&gt;&lt;/fn-group&gt;</pre>

### 10.1.5 Cross-references to abbreviations

IDs can be attributed to abbreviations in order to facilitate cross-referencing to them from inside the text.



To this purpose, a **<def-list>** is created (with *@list-content="abbreviation"*), listing all the abbreviations in **<term>** and their definitions in **<def>** inside **<def-item>**, which carries the ID of the **<term>-<def>** pair.

Any occurrences in the text can then be linked via **<xref>** to the respective **<def-item>**, providing the possibility, in the rendered content, to create for example a tooltip window for the user that will display the definition of any abbreviation on mouse-over.

For example:

4 Abbreviated terms	
ACSI	Abstract communication service interface
ASN.1	Abstract syntax notation one
API	Application program interface
CDC	Common data class
CT	Current transformer
DST	Daylight saving time

is coded as:

```
<sec id="sec-4">
<label>4</label>
<title>Abbreviated terms</title>
<def-list list-content="abbreviation">
<def-item id="abb-acsi">
<term>ACSI</term>
<def>
<p>Abstract communication service interface</p></def></def-item>
```

and can then be referred to later in the document like this:

Each part defines a specific aspect of a substation **IED**:

coded as:

```
<p id="p-65">Each part defines a specific aspect of a substation <xref ref-type="other" rid="abb-ied">IED</xref>:</p>
```

### 10.1.6 Cross-references to items in bibliography

References to items in the bibliography are coded with **<xref>**.

#### Attributes

- *@ref-type* is **"bibr"**
- *@rid* contains the ID of the bibliographical entry to which the cross-reference is made

For example:

b) which does not achieve its primary intended action in or on the human body by pharmacological, immunological or metabolic means, but which may be assisted in its intended function by such means

NOTE The term "medical device" is usually defined by national regulations. For the purposes of this International Standard, this definition does not list "*in vitro* diagnostic medical devices" (see ISO 13485:2003, definition 3.7<sup>[1]</sup>).

### 3.29 monitoring

act of overseeing the progress of a clinical investigation and to ensure that it is conducted, recorded, and reported in accordance with the CIP, written procedures, this International Standard, and the applicable regulatory requirements

## Bibliography

[1] ISO 13485:2003, *Medical devices — Quality management systems — Requirements for regulatory purposes*

## 10.2 External References

This section describes how to tag references in the flow text of a standard. The markup of lists of references, e.g. the or the of a standard, is described in dedicated sections.

External references to other documents are tagged as

- **<std>** if the reference is to a standard
- **<mixed-citation>** if it is not

### 10.2.1 Reference to an external standard

For example:

#### 3 Terms and definitions

For the purposes of this document, the terms and definitions given in ISO 7183, ISO 8573-7 and the following apply.

is coded as:

```
<sec id="sec_3" sec-type="terms">
 <label>3</label>
 <title>Terms and definitions</title>
 <p>For the purposes of this document, the terms and definitions given in <std><std-ref>ISO
 7183</std-ref></std>, <std><std-ref>ISO 8573-7</std-ref></std> and the following apply.</p>
 ...
</sec>
```

### 10.2.2 Reference to a section, figure etc. in an external standard

References are also made to a particular section or other content element (figure, table, equation...) inside a standard. They are coded as follows:

## ISO

ISO/IEC Guide 98-3:2008 , 7.3.1; ISO 1234:2011, Equation (1)

is coded as:

```
<std><std-ref>ISO/IEC Guide 98-3:2008</std-ref>, 7.3.1</std>; <std><std-ref>ISO
1234:2011</std-ref>, Equation (1)</std>
```

## IEC

This part of IEC 60027 is intended to replace Clause 11 of IEC 60027-2:2000.

is coded as:

```
<p id="p-14">This part of <std><std-id std-id-link-type="urn" std-id-type="dated">
urn:iec:std:iec:60027-6:2006-12:::</std-id><std-ref>IEC 60027</std-ref></std> is
intended to replace <std><std-id std-id-link-type="urn" std-id-type="dated">
urn:iec:std:iec:60027-2:2000-11:::#sec-11</std-id><std-ref>Clause 11 of
IEC 60027‑2:2000</std-ref></std>.</p>
```

### 10.2.3 URL

A URL is coded using **<uri>**.

For example:

Further information is available at <http://my.url> on the interweb.

is coded as:

```
<p>Further information is available at <uri>http://my.url</uri> on the interweb.</p>
```

Incomplete URLs, e.g. URLs without *http://*, should be tagged with **<ext-link>**.

**<ext-link>** is also used when there is display text which hides the actual link. **@xlink:href** then contains the actual link.

For example:

For the purposes of research on service management standards, users are encouraged to share their views on ISO/IEC 20000-1 and their priorities for changes to the rest of the ISO/IEC 20000 series. Click on the link below to take part in the online survey.

[ISO/IEC 20000-1 online survey](http://www.surveymonkey.com/s/20000-1)

<http://www.surveymonkey.com/s/20000-1>

is coded as:

```
<p style-type="align-center"><ext-link xlink:href="http://www.surveymonkey.com/s/20000-
1">ISO/IEC 20000-1 online survey</ext-link></p>
```

## Annex A Metadata usage

### A.1 ISO

```
<std-meta>
<title-wrap xml:lang="en">
<intro>Glass in building</intro>
<main>Forced-entry security glazing</main>
<compl>Test and classification by repetitive ball drop</compl>
<full>Glass in building – Forced-entry security glazing – Part 1: Test and classification by
repetitive ball drop</full>
</title-wrap>
<title-wrap xml:lang="fr">
<intro>Verre dans la construction</intro>
<main>Vitrages de sécurité contre infractions</main>
<compl>Essai et classification par balle lancée répétée</compl>
<full>Verre dans la construction – Vitrages de sécurité contre infractions – Partie 1: Essai et
classification par balle lancée répétée</full>
</title-wrap>
<proj-id>75209</proj-id>
<release-version>DIS</release-version>
<std-ident>
<originator>ISO</originator>
<doc-type>IS</doc-type>
<doc-number>16936</doc-number>
<part-number>1</part-number>
<edition>2</edition>
<version>1</version>
</std-ident>
<std-org std-org-type="sdo">
<std-org-abbrev>ISO</std-org-abbrev>
</std-org>
<content-language>en</content-language>
<std-ref type="dated">ISO/DIS 16936-1</std-ref>
<std-ref type="undated">ISO/DIS 16936-1</std-ref>
<doc-ref>ISO/DIS 16936-1 (en)</doc-ref>
<comm-ref>ISO/TC 160/SC 2</comm-ref>
<secretariat>ANSI</secretariat>
<ics>81.040.20</ics>
<page-count count="8"/>
<std-xref type="revises">
<std-ref>ISO 16936-1:2005</std-ref>
</std-xref>
<permissions>
<copyright-statement>All rights reserved</copyright-statement>
<copyright-year>2020</copyright-year>
<copyright-holder>ISO</copyright-holder>
</permissions>
<self-uri>iso:std:iso:16936:-1:dis:ed-2:v1:en</self-uri>
<custom-meta-group>
<custom-meta>
<meta-name>price-ref-pages</meta-name>
<meta-value>8</meta-value>
</custom-meta>
<custom-meta>
<meta-name>generation-date</meta-name>
<meta-value>2020-01-31</meta-value>
</custom-meta>
</custom-meta-group>
</std-meta>
```



## A.2 IEC

```
<front>
 <std-meta>
 <title-wrap xml:lang="en">
 <full>Letter symbols to be used in electrical technology - Part 2: Telecommunications and
 electronics</full>
 </title-wrap>
 <permissions>
 <copyright-statement>
 <inline-graphic/>THIS PUBLICATION IS COPYRIGHT PROTECTED
Copyright © 2019 IEC,
 Geneva, Switzerland</copyright-statement>
 <copyright-year>2019</copyright-year>
 <copyright-holder>IEC</copyright-holder>
 <license>
 <license-p>All rights reserved. Unless otherwise specified, no part of this publication
 may be reproduced or utilized in any form or by any means, electronic or mechanical,
 including photocopying and microfilm, without permission in writing from either IEC or
 IEC’s member National Committee in the country of the requester. If you have any
 questions about IEC copyright or have an enquiry about obtaining additional rights to
 this publication, please contact the address below or your local IEC member National
 Committee for further information.</license-p>
 <license-p>
 <address>IEC Central Office, 3, rue de Varemé, CH-1211 Geneva 20, Switzerland,
 Tel.: +41 22 919 02 11, info@iec.ch, www.iec.ch</address>
 </license-p>
 <license_ref>http://xyz: reference to licensing conditions, e.g. code
 components</license_ref>
 </license>
 </permissions>
 <proj-id>iec:proj:19106</proj-id>
 <release-version>IS</release-version>
 <std-ident>
 <originator>IEC</originator>
 <doc-type>IS</doc-type>
 <doc-number>60027</doc-number>
 <part-number>2</part-number>
 <edition>4</edition>
 <std-id-group>
 <std-id originator="IEC" std-id-link-type="id" std-id-type="dated">iec:pub:30633</std-id>
 <std-id originator="IEC" std-id-link-type="ocid" std-id-type="dated">30633</std-id>
 <std-id originator="IEC" std-id-link-type="urn" std-id-type="dated">
 >urn:iec:std:iec:60027-2:2019-01:::</std-id>
 </std-id-group>
 <isbn>9782832263464</isbn>
 <suppl-type/>
 <suppl-number/>
 </std-ident>
 <std-org>
 <std-org-abbrev>IEC</std-org-abbrev>
 </std-org>
 <content-language>en</content-language>
 <std-ref type="dated">IEC 60027-2:2019</std-ref>
 <release-date date-type="published">2019-01-08</release-date>
 <meta-date type="stability-date">2021-12-31</meta-date>
 <comm-ref id="id_1215">TC 25</comm-ref>
 <ics>01.060</ics>
 <ics>33.020</ics>
 <counts>
 <page-count count="149"/>
 </counts>
 <self-uri xlink:type="simple" xmlns:xlink="http://www.w3.org/1999/xlink">
 >https://api.iec.ch/harmonized/publications/download/300160</self-uri>
 <abstract xml:lang="en">
 <p>IEC 60027-2:2019 is applicable to telecommunications and electronics. It gives names and
 symbols for quantities and their units.</p>
 </abstract>
 <custom-meta-group>
 <custom-meta>
 <meta-name>price code</meta-name>
 </custom-meta>
 </custom-meta-group>
 </std-meta>
</front>
```



```
<meta-value>iec:L</meta-value>
</custom-meta>
</custom-meta-group>
</std-meta>
<sec id="sec-foreword" sec-type="foreword">
```

### A.3 National metadata usage

The NISO metadata model allows for multiple instances of **<std-meta>**. This can be used for National metadata.





## Annex B Coding Tables in NISO STS

### B.1 General

Tables are coded using the XHTML 1.1 table model. OASIS modules for the OASIS XML Exchange table model (based on the CALS table model) have been included in NISO STS, therefore `<oasis:table>` may be used in addition to or in place of the XHTML `<table>` element.

However, this document will only describe tables using the XHTML 1.1 table model.

There are very few differences between JATS and NISO coding of tables; one notable difference is that `<caption>` is now a child of `<table-wrap>` and not of `<table>`.

### B.2 Text alignment of tables

#### B.2.1 Default vertical alignment of a table text

- Use the value “**top**” as the default value for `@valign`.
- This should be applied for the element `<col>` which will automatically define the text alignment of the complete column.
- Whenever the defined alignment changes visually within the table/column, the applicable alignment should be coded with `@valign` separately for that cell(s)

For example:

Table columns which have the alignment as visualized in the below images will be coded with `@valign="top"`. Only the red highlighted cells in Table G.37 will be considered as different.

**Table H.15 — Minimum combinations**

Combination	FWI	WTXM
1	0	1
2	0	3
3	0	59
4	1	1
5	1	3
6	1	59
7	14	1
8	14	3
9	14	59

Table H.2 — Type A specific test methods

Test method from ISO/IEC 10373-6		Corresponding requirement	
Clause	Name	Base standard	Clause
H.2.1	Frame delay time PICC to PCD	ISO/IEC 14443-3:—	6.2.1.2
H.2.2	Request Guard Time	ISO/IEC 14443-3:—	6.2.2
H.2.3	Handling of bit collision during ATQA	ISO/IEC 14443-3:—	6.5.2
H.2.4	Handling of anticollision loop	ISO/IEC 14443-3:—	6.5.3
H.2.5	Handling of RATS and ATS	ISO/IEC 14443-4:2008	5.6.1.1
H.2.6	Handling of PPS response	ISO/IEC 14443-4:2008	5.6.2.1
H.2.7	Frame size selection mechanism	ISO/IEC 14443-4:2008	5.2.3
H.2.8	Handling of Start-up Frame Guard Time	ISO/IEC 14443-4:2008	5.2.5
H.2.9	Handling of the CID during activation by the PCD	ISO/IEC 14443-4:2008	5.6.3

Table G.46 — Result criteria for Scenario G.26: Behavior of the PICC Type B in the HALT state

Explanation	Test result
Only when the PICC responded as indicated in the procedure	PASS
Any other case	FAIL

Table G.37 — State Transition

State → Next State	PICC-test-apparatus		PICC
POWER-OFF → IDLE	Power On (RF operating Field on)	→	
		←	Mute
IDLE → READY-REQUESTED	REQB(16)	→	
		←	Mute <sup>a</sup>
IDLE → READY-DECLARED	REQB(1)	→	
		←	ATQB
READY-DECLARED → HALT	HLTB	→	
		←	'00' CRC_B
READY-DECLARED → PROTOCOL	ATTRIB(0,0)	→	
		←	ATA(0)

<sup>a</sup> In case the PICC has selected slot 1, the REQB command shall be reissued until the PICC doesn't answer ATQB.

## B.2.2 Default horizontal alignment of a table text

In XHTML, the default alignment of a table cell data is defined as "left".

Use *@align="left"* whenever the table cell data is aligned left as well as when it is not clear visually whether the cell data is left aligned or centered.

When in doubt, this default value should be used.

### B.2.3 Default horizontal alignment of table header data

In XHTML, the default alignment of table header data is defined as "center".

Therefore, do not use *@align* when the table header data are aligned center in the source. *@align* should be coded with a different value only when the alignment differs.

This does not depend on the alignment used for `<col>`.

### B.2.4 Merged cells

Merged cells are captured by *@rowspan* or *@colspan* in `<td>` within `<table>`. The value of *@rowspan* or *@colspan* must be the number of rows and columns being merged. Default value for both is 1; in order to merge cells, the value should be higher than 1.

For example:

Table A.3 — Speed — Engine or Ground Speed

Control type	Location	Operation requirements and examples
Hand-operated single lever control	At the option of the manufacturer	Forward or downward motion shall increase speed. Rearward or upward motion shall decrease speed.
Finger-operated buttons	At the option of the manufacturer	Pushing the acceleration button or switch shall increase speed. Pushing the deceleration button or switch shall decrease speed.
Finger-operated dial	At the option of the manufacturer	Turning the dial clock-wise shall increase speed. Turning the dial counter clock-wise shall decrease speed.
Foot-operated single pedal control	Available to operator's right foot	Downward or forward motion shall increase speed. Upward or rearward motion shall decrease speed.
	Available to operator's right foot	For crawler dozers downward or forward motion shall decrease speed.

is coded as:

```
<tr>
 <td align="left" rowspan="2" scope="row" style="border-left: solid 2px; border-top: solid 1px; border-right: solid 1px; border-bottom: solid 2px" valign="top">Foot-operated
single pedal control</td>
 <td align="left" style="border-left: solid 1px; border-top: solid 1px; border-right: solid 1px; border-bottom: solid 1px" valign="top">Available to operator's right foot</td>
 <td align="left" style="border-left: solid 1px; border-top: solid 1px; border-right: solid 2px; border-bottom: solid 1px" valign="top">Downward or forward motion shall increase speed.<p>Upward or rearward motion shall decrease speed.</p></td>
</tr>
```

### B.2.5 Line breaks and lists within a table

Line breaks should only occur if technically significant or if required for output appearance.

Whenever the soft return is used for the line breaks within a table, it should be coded with `<break/>` element within the cell.

Élément-clé	Niveau de maturité vers des performances durables				
	Niveau 1	Niveau 2	Niveau 3	Niveau 4	Niveau 5
Élément 1	Critère 1 Niveau de base				Critère 1 Meilleure pratique
Élément 2	Critère 2 Niveau de base				Critère 2 Meilleure pratique
Élément 3	Critère 3 Niveau de base				Critère 3 Meilleure pratique

Whenever the hard return is used for the line breaks it should be coded with **<p>** element within the cell.

Tableau A.1 — Éléments-clé d'auto-évaluation — Corrélation entre les éléments-clés et les niveaux de maturité

Élément-clé	Niveau de maturité				
	Niveau 1	Niveau 2	Niveau 3	Niveau 4	Niveau 5
Quel est le centre d'intérêt du management? (Gestion)	L'intérêt se porte sur les produits, actionnaires et certains clients, avec des réponses ponctuelles aux changements, problèmes et opportunités.	L'intérêt se porte sur les clients et les exigences légales/réglementaires, avec une réponse relativement structurée aux problèmes et opportunités.	L'intérêt se porte sur le personnel et quelques autres parties intéressées. Des processus sont définis et mis en œuvre en réponse aux problèmes et aux opportunités.	L'intérêt se porte sur l'équilibre des besoins des parties intéressées identifiées. Parmi les centres d'intérêt de l'organisme, l'accent est mis sur l'amélioration continue.	L'intérêt se porte sur l'équilibre des besoins des parties intéressées émergentes. Des performances optimales sont définies comme principal objectif.
Quelle est l'approche du leadership? (Gestion)	L'approche est réactive et fondée sur des instructions descendantes.	L'approche est réactive et fondée sur les décisions des managers à différents niveaux.	L'approche est proactive et le pouvoir décisionnel est délégué.	L'approche est proactive, avec une forte implication du personnel de l'organisme dans la prise de décision.	L'approche est proactive et orientée apprentissage, avec l'habilitation du personnel à tous les niveaux.

For example:

```
<td>content before the hard return. <p>content after the 1st hard return</p><p>content after the 2nd hard return</p></td>
```

**<list>** is allowed in table cells. Lists should only be used if there is more than one item within the cell. The formatting of other text in the cell does not have to match the formatting of the list.

For example:

7.4.2	Pár. 1	A	La información de las compras debe describir el producto a comprar, incluyendo, cuando sea apropiado: <ul style="list-style-type: none"> <li>a) los requisitos para la aprobación del producto, procedimientos, procesos y equipos,</li> <li>b) los requisitos para la calificación del personal, y</li> <li>c) los requisitos del sistema de gestión de la calidad.</li> </ul>
7.5.1	Punto d)	S + A	d) la disponibilidad y uso de dispositivos/equipos de seguimiento y medición,
7.5.1	Punto f)	A	f) la implementación de actividades de liberación, entrega y posteriores a la entrega del producto.
7.5.2	Pár. 1	S + A	La organización debe validar aquellos procesos todo proceso de producción y de

Please note the two cells below the outlined cell contain only one item of the list. Cases like these should be coded as normal text, not as a **<list>**.

## B.3 Other instructions

### B.3.1 Landscape tables

Tables with landscape orientation are coded with `@orientation="landscape"`.

For example:

```
<table-wrap id="tab_a" orientation="landscape" position="float">...</table-wrap>
```

ISO 1101:2004(E)

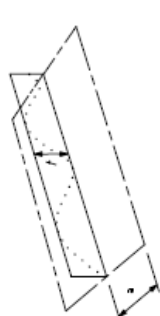
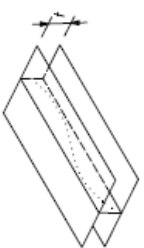
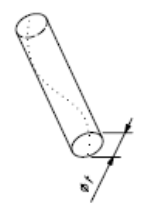
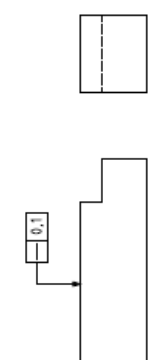
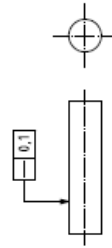
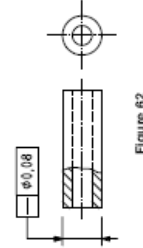
Symbol	Definition of the tolerance zone	Indication and explanation
<p>18.1 Straightness tolerance (see ISO/TS 12780-1 and ISO/TS 12780-2)</p> <p>The tolerance zone, in the considered plane, is limited by two parallel straight lines a distance <math>t</math> apart and in the specified direction only.</p>	<p style="text-align: center;">    <b>Figure 57</b> </p> <p>* Any distance.</p> <p>The tolerance zone is limited by two parallel planes a distance <math>t</math> apart.</p> <p style="text-align: center;">    <b>Figure 59</b> </p> <p>The tolerance zone is limited by a cylinder of diameter <math>t</math>, if the tolerance value is preceded by the symbol <math>\phi</math>.</p> <p style="text-align: center;">    <b>Figure 61</b> </p>	<p style="text-align: center;">    <b>Figure 58</b> </p> <p>Any extracted (actual) line on the upper surface, parallel to the plane of projection in which the indication is shown, shall be contained between two parallel straight lines 0,1 apart.</p> <p style="text-align: center;">    <b>Figure 60</b> </p> <p>Any extracted (actual) generating line on the cylindrical surface shall be contained between two parallel planes 0,1 apart.</p> <p>NOTE: The definition for an extracted generating line has not been standardized.</p> <p style="text-align: center;">    <b>Figure 62</b> </p> <p>The extracted (actual) median line of the cylinder to which the tolerance applies shall be contained within a cylindrical zone of diameter 0,08.</p>

Dimensions in millimetres

© ISO 2004 – All rights reserved 17

### B.3.2 Tables lines via attributes

General lines and table layouts should be coded with *@style*. This attribute can be specialized across the entire table, avoiding the need to replicate information for every cell. Using *@style* can also reduce the overall byte size required for the tables.

1. Use *@style* for **<table>** in order to code the table frame

E.g.:

```
<table frame="box" rules="all" cellspacing="0" cellpadding="0" style="border-collapse:collapse;border:solid 2px;">
```

Output:

header 1	header 2
content 1	description for content 1
content 2	description for content 2
content 3	description for content 3
content 4	description for content 4

2. Use *@style* for **<col>** for entire column framing, i.e. when the frame is applicable for the whole column. This will avoid coding *@style* for each and every cell applicable.

E.g.:

```
<table frame="box" rules="all" cellspacing="0" cellpadding="0" style="border-collapse:collapse;">
<colgroup>
<col width="100" align="left" valign="top" />
<col width="100" align="left" valign="top" style="border:solid 3px;" />
<col width="100" align="left" valign="top" />
</colgroup>
```

Output:

header 1	header 2	header 3
content 1	description 1	content 1
content 2	description 2	content 2
content 3	description 3	content 3
content 4	description 4	content 4

### B.3.3 Using table rules attribute

Table *@rules* declares where borders are drawn between cells.

Output differs in different browsers. ISO and IEC do not currently use *@rules*.

1. *@rules="rows"*

```
<table rules="rows">
```

Output:



1	2	3	4
sda	asdasd	dasd	asd
asda	asds	asd	asd
sasd	asd	sd	asd
asdag	as	asd	sd

The output displays the table attribute rules=rows. A table of four rows has been used. Rules have been drawn **above** the rows.

## 2. @rules="cols"

```
<table rules="cols">
```

Output:

1	2	3	4
sda	asdasd	dasd	asd
asda	asds	asd	asd
sasd	asd	sd	asd
asdag	as	asd	sd

## 3. @rules="all"

```
<table rules="all">
```

Output:

Table rules for rows and columns.

1	2	3	4
sda	asdasd	dasd	asd
asda	asds	asd	asd
sasd	asd	sd	asd
asdag	as	asd	sd

## 4. @rules="groups"

```
<table rules="groups">
```

Output:

Web Browser	Filtering Features							
	Cookies			Images			Pop-Up Windows	
	external server	by domain	throw away on exit	external server	by domain	by URL	all	by domain
Internet Explorer	Yes	Yes	No	No	No	No	No	No
Mozilla	Yes	Yes	Yes	Yes	Yes	No	Yes	Yes
Opera	Yes	Yes	Yes	No	No	No	Yes	No
iCab	No	No	Yes	Yes	Yes	Yes	No	No

This table has rules="groups". It should only have rules between the row groups (between the header and body) and between the column groups:

### B.3.4 Table frames

Table frames are used when drawing borders for a table. Different values in the *@frame* attribute will enable different types of output.

While IEC makes use of *@frame*, ISO does not currently use this attribute.

#### 1. *@frame = "box"*

This will draw a box around the table.

Output:

Web Browser	Filtering Features							
	Cookies			Images			Pop-Up Windows	
	external server	by domain	throw away on exit	external server	by domain	by URL	all	by domain
Internet Explorer	Yes	Yes	No	No	No	No	No	No
Mozilla	Yes	Yes	Yes	Yes	Yes	No	Yes	Yes
Opera	Yes	Yes	Yes	No	No	No	Yes	No
iCab	No	No	Yes	Yes	Yes	Yes	No	No

#### 2. *@frame = "hside"*

This will draw borders on the top and bottom sides only.

Output:

Web Browser	Filtering Features							
	Cookies			Images			Pop-Up Windows	
	external server	by domain	throw away on exit	external server	by domain	by URL	all	by domain
Internet Explorer	Yes	Yes	No	No	No	No	No	No
Mozilla	Yes	Yes	Yes	Yes	Yes	No	Yes	Yes
Opera	Yes	Yes	Yes	No	No	No	Yes	No
iCab	No	No	Yes	Yes	Yes	Yes	No	No

#### 3. *@frame = "vside"*





This will draw borders on the left and right sides only.

Output:

Web	Filtering Features							
	Cookies		Images			Pop-Up Windows		
Browser	external server	by domain	throw away on exit	external server	by domain	by URL	all	by domain
Internet Explorer	Yes	Yes	No	No	No	No	No	No
Mozilla	Yes	Yes	Yes	Yes	Yes	No	Yes	Yes
Opera	Yes	Yes	Yes	No	No	No	Yes	No
iCab	No	No	Yes	Yes	Yes	Yes	No	No

4. @frame = "above"

This will draw a border above the table.

Output:

Web	Filtering Features							
	Cookies		Images			Pop-Up Windows		
Browser	external server	by domain	throw away on exit	external server	by domain	by URL	all	by domain
Internet Explorer	Yes	Yes	No	No	No	No	No	No
Mozilla	Yes	Yes	Yes	Yes	Yes	No	Yes	Yes
Opera	Yes	Yes	Yes	No	No	No	Yes	No
iCab	No	No	Yes	Yes	Yes	Yes	No	No

5. @frame = "below"

This will draw a border below the table

Output:

Web	Filtering Features							
	Cookies		Images			Pop-Up Windows		
Browser	external server	by domain	throw away on exit	external server	by domain	by URL	all	by domain
Internet Explorer	Yes	Yes	No	No	No	No	No	No
Mozilla	Yes	Yes	Yes	Yes	Yes	No	Yes	Yes
Opera	Yes	Yes	Yes	No	No	No	Yes	No
iCab	No	No	Yes	Yes	Yes	Yes	No	No

6. @frame = "lhs"

This will draw a border on the left hand side of the table.

Output:

Web Browser	Filtering Features				Images		Pop-Up Windows	
	external server	cookies by domain	throw away on exit	external server	by domain	by URL	all	by domain
Internet Explorer	Yes	Yes	No	No	No	No	No	No
Mozilla	Yes	Yes	Yes	Yes	Yes	No	Yes	Yes
Opera	Yes	Yes	Yes	No	No	No	Yes	No
iCab	No	No	Yes	Yes	Yes	Yes	No	No

7. @frame = "rhs"

This will draw a border on the right hand side.

Output:

Web Browser	Filtering Features				Images		Pop-Up Windows	
	external server	cookies by domain	throw away on exit	external server	by domain	by URL	all	by domain
Internet Explorer	Yes	Yes	No	No	No	No	No	No
Mozilla	Yes	Yes	Yes	Yes	Yes	No	Yes	Yes
Opera	Yes	Yes	Yes	No	No	No	Yes	No
iCab	No	No	Yes	Yes	Yes	Yes	No	No

### B.3.4 Border styling

Styling borders with different colors, border widths and patterns can be done in @style. This can be done at the cell or entire table level, see [NISO guidelines on the use of @style](#).

Examples of various border settings are shown below.

A	B
111	222
555	666
999	000
1414	1515

```

<tr>
 <th style="border-right: 3px double red; border-top-style: dotted;
border-top-color: red; border-top-width: 2px; border-bottom-style: dashed;
border-bottom-color: blue; border-bottom-width: 2px; border-left-style: dotted;
border-left-color: green; border-left-width: 2px; color: red;" >A</th>
 <th>B</th>
 <th>C</th>
 <th>D</th>

```

### B.3.5 Alignment of Table

Alignment of tables on the page will not be coded into the table. This will instead be handled by scripting or rendering depending on the end format.

No special alignment will be coded for the tables which are center aligned in the source page.

### B.3.6 Text rotation

Text rotation in tables is handled through *@style* as follows:

E.g.: *@style="transform: rotate(-90deg);"*

Internet Explorer does not support the correct view for this coding. It was assumed that the final view at the client's end is capable of retaining the provided value for *@style*.

While IEC is using this value, ISO is not currently using it, but intends to in the future.

Table A.1 — Evaluation tests for consideration

Medical device categorization by			Biological effect							
nature of body contact (see 5.2)		contact duration (see 5.3)	Cytotoxicity	Sensitization	Irritation or intracutaneous reactivity	Systemic toxicity (acute)	Subchronic toxicity (subacute toxicity)	Genotoxicity	Implantation	Haemocompatibility
Category	Contact	A – limited (≤ 24 h) B – prolonged (> 24 h to 30 d) C – permanent (> 30 d)								
Surface device	Skin	A	X <sup>a</sup>	X	X					
		B	X	X	X					
		C	X	X	X					
	Mucosal membrane	A	X	X	X					
		B	X	X	X					



## Annex C Amendments

### IEC amendments

IEC amendments are generally coded as a regular IEC standard would, with semantic tagging wherever possible. Where it isn't possible, due to the constraints of amendment-specific editing, a layout-based option will be used.

### Editing instructions

Instructions such as "Insert the following text" or "Delete ..." are coded inside **<editing-instruction>** (see also 5.14).

Example:

**3 Terms and definitions**

*Add, after the existing definition 3.22 in CISPR 11:2015/AMD1:2016, the following new term and definition:*

**3.23**  
**power conversion equipment**  
electrical device converting one form of electrical power to another form of electrical power with respect to voltage, current, frequency, phase and the number of phases

[SOURCE: IEC 62920:2017 3.3]

**6.2.1.1 General**

*Replace the last paragraph by the following new paragraph:*

The limits for the LV d.c. power ports specified hereafter apply only to the following types of equipment:

is coded as:

```
<title>Terms and definitions</title>
<editing-instruction content-type="addition">
<p id="p-34"><italic>Add, after the existing <std><std-id std-id-link-type="urn" std-id-
type="dated">urn:iec:std:cispr:11:2015-06::||amd:1:2016-06#con-3.22</std-id><std-ref>definition
3.22 in CISPR 11:2015/AMD1:2016</std-ref></std>, the following new term and
definition:</italic></p></editing-instruction>
<term-sec id="con-3.23">
<label>3.23</label>
<tbx:termEntry id="te-3.23">
<tbx:langSet xml:lang="en">
<tbx:definition>electrical device converting one form of electrical power to another form of
electrical power with respect to voltage, current, frequency, phase and the number of
phases</tbx:definition>
<tbx:source>SOURCE: <std><std-id std-id-link-type="urn" std-id-
type="dated">urn:iec:std:iec:62920:2017-07::#con-3.3</std-id><std-
ref>IEC 62920:2017 3.3</std-ref></std></tbx:source>
<tbx:tig>
<tbx:term id="ter-power_conversion_equipment">power conversion equipment</tbx:term>
```



```
<tbx:partOfSpeech value="noun"/>
<tbx:normativeAuthorization value="preferredTerm"/>
<tbx:termType value="fullForm"/></tbx:tig></tbx:langSet></tbx:termEntry></term-sec>
<sec id="sec-6.2.1.1">
<label>6.2.1.1</label>
<title>General</title>
<editing-instruction content-type="replacement">
<p id="p-35"><italic>Replace the last paragraph by the following new
paragraph:</italic></p></editing-instruction>
<p id="p-36">The limits for the LV d.c. power ports specified hereafter apply only to the following
types of equipment:</p>
```



## ISO amendments

ISO produces amendment texts separate from the original document. The XML captures the text of the amendment without semantic instruction for deletion or addition, and without direct reference to the original document.

For example:

### *3.1, 3.2*

Change all references to "*datatype (3.1.8)*" to "*datatype (3.1.9)*".

### *3.1.13*

Change the reference in the source from "7.3.37" to "7.3.38".

### *3.2.9*

Replace the definition with:

*attribute (3.1.4)* of a *metadata item (3.2.75)* commonly needed in its specification

### *3.2.50*

Replace the definition with:

*metadata item (3.2.75)* which can have *designations (3.2.51)* and/or *definitions (3.2.40)*

is coded as:

```
<body>
<sec id="section_1"><label/>
<p> </p>
<p><i>3.1, 3.2</i></p>
<p>Change all references to "<i>datatype</i> (3.1.8)" to
"<i>datatype</i> (3.1.9)".</p>
<p> </p>
<p><i>3.1.13</i></p>
<p>Change the reference in the source from "7.3.37" to "7.3.38".</p>
<p> </p>
<p><i>3.2.9</i></p>
<p>Replace the definition with:</p>
<p><i>attribute</i> (3.1.4) of a <i>metadata item</i> (3.2.75)
commonly needed in its specification</p>
<p> </p>
<p><i>3.2.50</i></p>
<p>Replace the definition with:</p>
<p><i>metadata item</i> (3.2.75) which can have <i>designations</i>
(3.2.51) and/or <i>definitions</i> (3.2.40)</p>
<p> </p>
```



Terms and definitions in amendments are captured in TBX.

For example:

3.2

Add the following new terms and definitions:

**3.2.143**

**conceptual domain definition**

formal definition of a *defined conceptual domain* ([3.2.144](#))

Note 1 to entry: The definition may reference externally enumerated value meanings.

**3.2.144**

**defined conceptual domain**

conceptual domain (3.2.21) that is specified by a formal definition

Note 1 to entry: The definition may reference externally enumerated value meanings.

**3.2.145**

**defined value domain**

value domain (3.2.140) that is specified by reference to an external specification

Note 1 to entry: The external specification should enumerate the permissible values.

is coded as:

```
<p><i>3.2</i></p>
<p>Add the following new terms and definitions:</p>
</sec>
<sec id="sec_terms" sec-type="terms"><label/>
<term-sec id="sec_3.2.143"><label>3.2.143</label>
<tbx:termEntry id="term_3.2.143">
<tbx:langSet xml:lang="en">
<tbx:definition>formal definition of a <tbx:entailedTerm target="term_3.2.144">defined
conceptual domain (3.2.144)</tbx:entailedTerm></tbx:definition>
<tbx:note>The definition may reference externally enumerated value meanings.</tbx:note>
<tbx:tig id="term_3.2.143-1">
<tbx:term>conceptual domain definition</tbx:term>
<tbx:partOfSpeech value="noun"/>
</tbx:tig></tbx:langSet>
</tbx:termEntry>
</term-sec>
<term-sec id="sec_3.2.144"><label>3.2.144</label>
<tbx:termEntry id="term_3.2.144">
<tbx:langSet xml:lang="en">
<tbx:definition>conceptual domain (3.2.21) that is specified by a formal
definition</tbx:definition>
<tbx:note>The definition may reference externally enumerated value meanings.</tbx:note>
<tbx:tig id="term_3.2.144-1">
<tbx:term>defined conceptual domain</tbx:term>
<tbx:partOfSpeech value="noun"/>
</tbx:tig></tbx:langSet>
</tbx:termEntry>
</term-sec>
<term-sec id="sec_3.2.145"><label>3.2.145</label>
<tbx:termEntry id="term_3.2.145">
<tbx:langSet xml:lang="en">
<tbx:definition>value domain (3.2.140) that is specified by reference to an external
specification</tbx:definition>
<tbx:note>The external specification should enumerate the permissible values.</tbx:note>
<tbx:tig id="term_3.2.145-1">
<tbx:term>defined value domain</tbx:term>
<tbx:partOfSpeech value="noun"/>
</tbx:tig></tbx:langSet>
</tbx:termEntry>
</term-sec>
</sec>
```





## Annex D

### IEC Corrigenda

When a corrigendum is published, its contents are integrated into the base publication associated with it. The XML of the base file will be updated with these changes by IEC and delivered in the usual ways.

### IEC Interpretation Sheets (ISH)

Interpretation sheets provide complementary contents to a base document. When an ISH is published, a link to the PDF of the ISH is integrated into the base publication associated with it. The PDF of the ISH is included in the assets, and an `@xlink:href` to it is integrated in an element `<supplementary-material>` inside the paragraph in the foreword that mentions that an ISH has been included.

For example, this text in the base document

The committee has decided that the contents of this document will remain unchanged until the stability date indicated on the IEC website under "http://webstore.iec.ch" in the data related to the specific document. At this date, the document will be

- reconfirmed,
- withdrawn,
- replaced by a revised edition, or
- amended.

*x-link* ↙

The contents of the interpretation sheet of March 2020 have been included in this copy.

is coded as

```
<p id="p-19"><supplementary-material xlink:href="asset/iec60079-11-12.pdf">The contents of the interpretation sheet of March 2020 have been included in this copy.</supplementary-material></p>
```

The assets folder contains the PDF of the ISH:

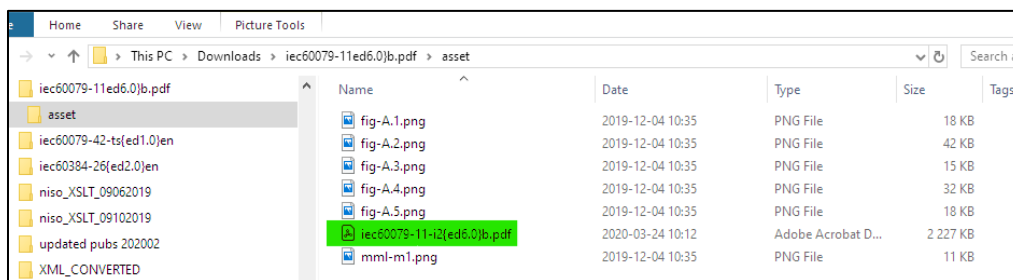

### IEC Software supplements

IEC standards are sometimes published with so-called Software supplements, a separate download or CD with one or more additional files accompanying the publication, which are intended to support the users in applying the standard, e.g. Excel worksheets to calculate values, computer code in various formats etc.



Software supplements are indicated in the foreword of the standard, through a sentence similar to this:

The list of all currently available parts of the ISO/IEC 14543 series, under the general title *Information technology – Home electronic system (HES) architecture*, can be found on the IEC website and ISO website.

This publication contains attached files in the form of xml. These files are intended to be used as a complement and do not form an integral part of the publication.

The text of this standard is based on the following documents:

In XML, the additional files in a Software supplement are contained in the asset folder. In the **<p>** containing the sentence, a link to these files will be created via *@xlink:href*, inside an element **<supplementary-material>**.

Here's the XML tagging of the above example:

```
<p id="p-12"><supplementary-material xlink:href="asset/software-supplement.xml"> This publication contains attached files in the form of xml. These files are intended to be used as a complement and do not form an integral part of the publication.</supplementary-material></p>
```



## Annex E IEC ID scheme

The ID scheme is meant to enable the creation of links at the level of elements across standards for the duration of the conversion from Word to XML. The implementation of an authoring system based on XML will make this scheme obsolete.

Element	With Label/Title			Without Label/Title		
	Label/Title/Content	Example	Comments	Title/Title	Example	Comments
Section	1.	sec-1		Foreword	sec-foreword	
	1.2.1.	sec-1.2.1		Introduction	sec-introduction	
				Bibliography	sec-bibliography	
				Index	sec-index	
Annex	B.1.	sec-B.1				
	B.1.2.	sec-B.1.2				
	Annex A	anx-A				
	Annex B	anx-B				
Bibliography	1.	bib-1		no text	bib-5	5th reference of bibliography
Concept	3.2.1	con-3.2.1				
Term entry		te-3.2.1				
Terms	broadcast	ter-broadcast				
Note to entry	Note	nte-3.4-1	1st note of terms in section 3.4			
Table	Table 1	tab-1		no title	tab-informal-5.3-1	1st informal table of section 5.3
				no title	tab-informal-5.3-2	2nd informal table of section 5.3
Figure	Figure 1	fig-1				
Formula	(1)	for-1		no text	for-informal-5.6-1	1st formula without label in the section 5.6
Math element				no own label (the parent formula may have one)	mml-1	sequentially numbered throughout the document, link to the corresponding .png graphics file can be based on this ID
Footnote	1	foo-1				
	2	foo-2				
	*	fos-1	1st footnote with a symbol in the document			
	‡	fos-2	2nd footnote with a symbol in the document			

Element	With Label/Title			Without Label/Title		
	Label/Title/Content	Example	Comments	Title/Title	Example	Comments
Table footnote	1	tfn-1-1	1st footnote of Table 1	*	tfn-3-1	1st table-footnote of Table 3
	2	tfn-1-2	2nd footnote of Table 1	‡	tfs-4-1	1st symbol table-footnote of Table 4
Figure note	Note	fno-4-1	1st note of Figure 4			
	Note 1	fno-5-2	2nd note of Figure 5			
Figure group note						
Table note	Note	tno-4-1	1st note of Table 4			
	Note 1	tno-5-2	2nd note of Table 5			
List item	2	lis-5.6-L1-2	2nd list item of 1st list of section 5.6			
	3	lis-5.6-L1-L2-3	3rd list-item of 2nd list item of 1st list of section 5.6			
Note	1	not-3.5-1	1st note of section 3.5			
Example						
Paragraph					p-450	450th paragraph of the document

## Annex F ISO ID scheme

Element	With Label/Title			Without Label/Title		
	Label/Title/ Content	Example	Comments	Title/Title	Example	Comments
Section	1.	sec_1		Foreword	sec_foreword	
	1.2.1.	sec_1.2.1		Introduction	sec_intro	
				Bibliography	sec_bibl	
				Index	sec_index	
Annex	B.1.	sec_B.1		-	-	
	B.1.2.	sec_B.1.2		-	-	
	Annex A	sec_A		-	-	
	Annex B	sec_B		-	-	
Bibliography	1.	ref_1		no text	ref_5	5th reference of bibliography
Terms	3 Terms and Definitions	sec_3		-	-	
Note to entry	Note	<tbx:note>		-	-	
Table	Table 1	tab_1		no title	tab_r	can use any letter not associated with an annex number
Figure	Figure 1	fig_1				
Formula	(1)	formula_1		no text	no id on inline formulae	
Footnote	1	fn_1		no text	fn_1	
	*	fn_2	Symbols are placed in labels; id numbering continues sequentially	-	-	
Table footnote	1	table-fn_1.1	1 <sup>st</sup> note of Table 1	no text	table-fn_1.1	
	a	table-fn_2.1	1st note of Table 2	-	-	
Figure note	Note	-	No id attribute in <non-normative-note>	-	-	
	Note 2	-	No id attribute in <non-normative-note>	-	-	
Figure group note	-	-	-	-	-	
Table note	Note	-	No id attribute in <non-normative-note>	-	-	
List item	a), 1, A	-	No id attribute in any <list> or <list-item>	-	-	
Note	-	-	No id attribute used on general notes	-	-	



Element	With Label/Title			Without Label/Title		
	Label/Title/ Content	Example	Comments	Title/Title	Example	Comments
Example	-	-	No id attribute used for examples	-	-	
Paragraph	-	-	No ids or other attributes used for <p>	-	-	